

# Grey Thunder



## 1:10 scale radio controlled nitro racing car



Length Overall:820mm(32.28")	Screw :D40-1.6(GP)/D42-1.4(EP)
Width :270mm(10.63")	Weight :GP-1.90Kgs(4.22Lbs)
Height :190mm(7.48")	EP-2.00Kgs/2.50Kgs(4.44Lbs/5.56Lbs)
power :GP-.16 Marine Engine	Drive System :Shaft Drive System
EP-Motor550/Motor775	Duration of Cruising(app):5 min(75cc)

Thank you for purchasing CEN racing's Grey Thunder high performance boat. Please understand that this is not a toy. It will require maintenance to ensure many hours of enjoyment. Please read and fully understand this entire instruction / manual before you assemble or use this model. You may miss important information that could result in you damaging your boat. If you have any questions please feel free to contact your local dealer, or ask an experienced modeler.

### Safety Precautions

Please read and follow these steps to help you not hurt anybody or damage anything when using this model.

- \*User must use common sense when using this boat. You, as the operator, take full responsibility for the use or miss-use of this model. This includes damage caused to the boat or to any property you may hit.
- \*Always check with others around you for frequency conflicts. If there is someone else on the same channel as you, make sure they have completely turn off their transmitter and model before you turn yours on. Not doing so may damage one or both of the models.
- \*Only use Model engine fuel. Don't use gasoline, kerosene, etc. They will destroy your engine and may cause a fire.
- \*Never dispose a battery into a fire.
- \*Always watch out for the prop. Contact with the running prop can and will cause serious damage.
- \*Never use your boat in dangerous conditions.

### Boat Maintenance

Please pay close attention to the following; this is important information for the well being of your boat.

- \*Never leave fuel or fuel residue on the hull. Some fuels will eat away the plastic and destroy your hull.
- \*Clean your boat with a mild detergent and water.
- \*Check all screws to make sure they are tight.
- \*Always make sure to keep your electronics dry. Contacts between the batteries and or plugs may become corroded.
- \*Never run the boat with debris around the prop. This will overheat the engine and possibly cause damage.
- \*If you have a nitro engine, make sure the water-cooled head is not clogged with debris. This can be check by looking for water exiting the side of the hull.

※SPECIFICATIONS ARE SUBJECT TO CHANGE WITHOUT PRIOR NOTICE.

20020400  
PRINTED IN TAIWAN

G00202002

# TOOLS

The following tools are necessary to make assembly & maintenance of your new R/C model. Both easier & more enjoyable. For your safety, exercise care when using any hand tools, sharp instruments, or power tools during construction. Always use safety glasses. If you have any questions, please consult your local hobby shops or experienced friends.

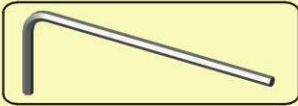

**Hexagon wrench** (kit tools supplied)  
1.5mm, 2mm, 2.5mm.



**Flat blade screwdriver**



**Cross wrench** (hexagon socket tools)  
5.5mm, 7mm, 8mm, 10mm, 12mm, 17mm.



**Phillips screwdriver**



**Hobby scissors**  
For cutting and trimming the car's body, decals.



**Needle nose pliers**  
Clamping parts during work of assembling and disassembling



**Grease**  
Lubrication of gears; reduces friction.



**Ruler**



**Glue**  
Use to glue tires onto the wheels; temporary repairs.  
**!** Always use hand and eye protection when using cyanoacrylic glue.



Soldering iron (40~50 watts) and a small amount of solder.  
**!** Be careful on hot parts



**Threadlock**  
For locking screws and nuts to prevent loosening.



**Liquid dish soap**



**Hobby knife**  
Use for trimming and cutting.  
**!** This knife cuts plastic and fingers with equal ease, so be careful



**Hand drill**  
2mm, 3mm, 6mm.

# REQUIRED FOR OPERATION

2CH. Transmitter

Fuel Bottle

AA Battery-12pcs

Glow Starter

Glow Charger

Servo Ch1, Ch2



Glow Fuel

Battery Pack

Plug Socket Wrench

Engine

Receiver

**01** Hull painting (*Grey Thunder*)

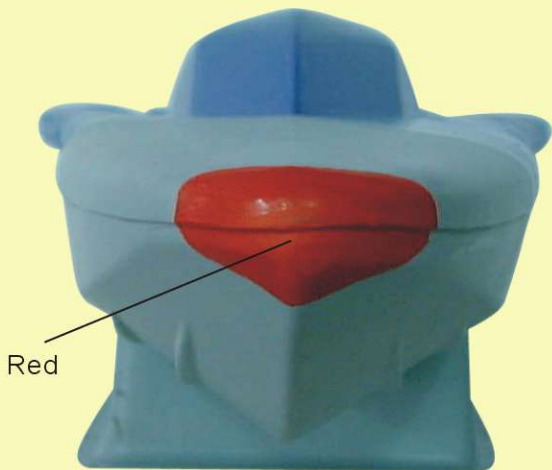
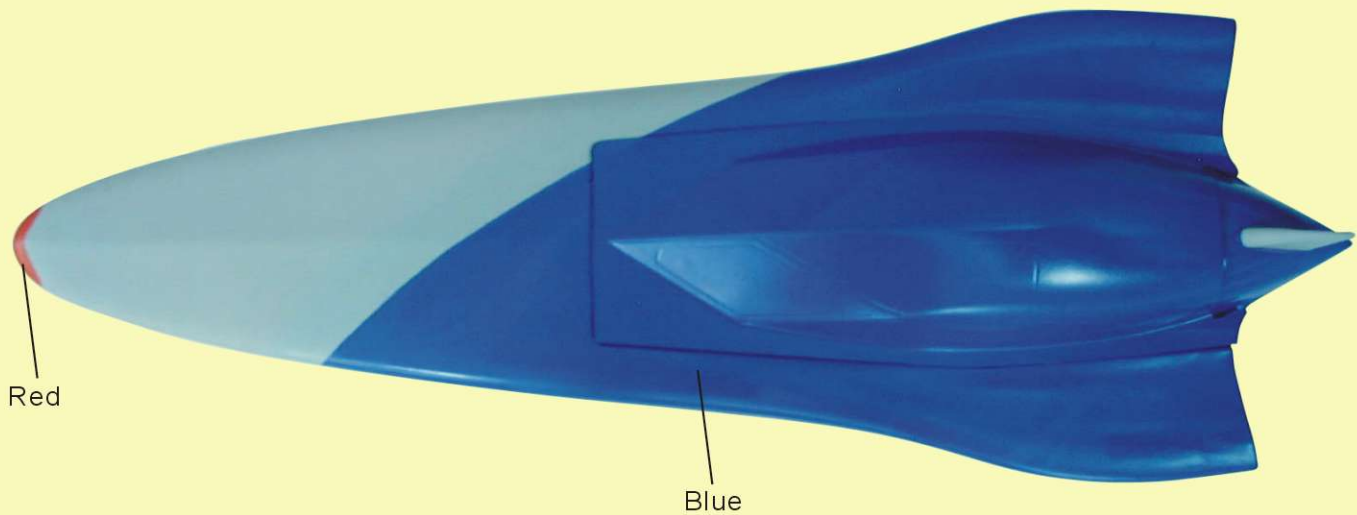
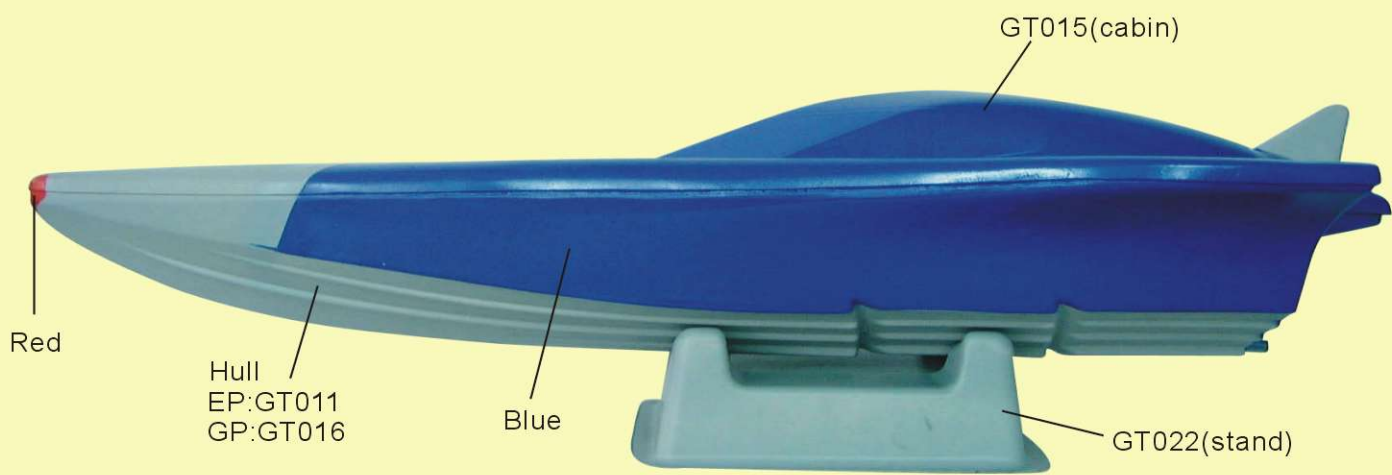

## 02 Rudder

GP EP

1. Install 2pcs 4x8x3 bushings into the rudder extension.
2. Insert the hinge pin through both the rudder mount and rudder extension.
3. Secure the hinge pin with the supplied set screw.

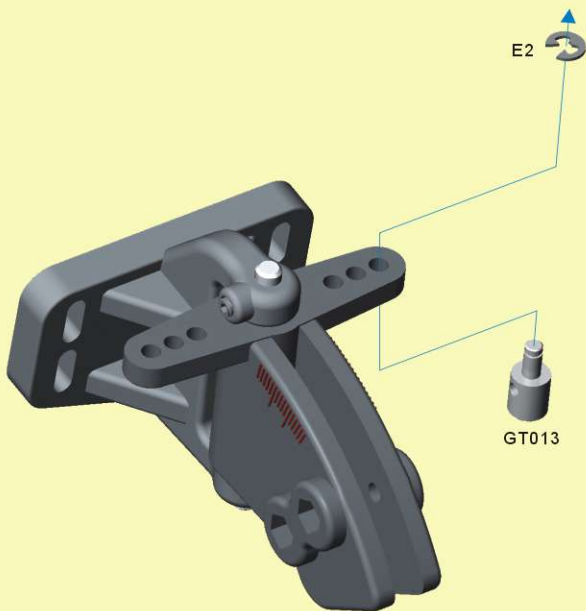
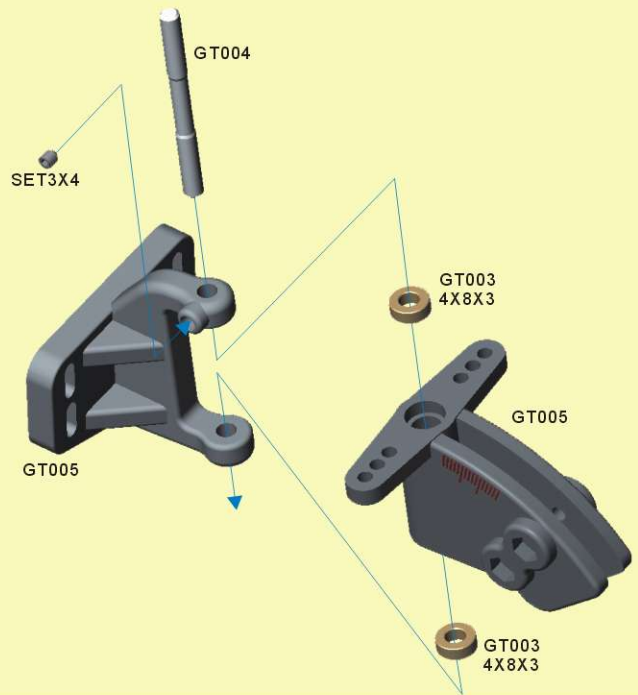

Secure the pivot joint to the 3rd hole using an "E" clip.

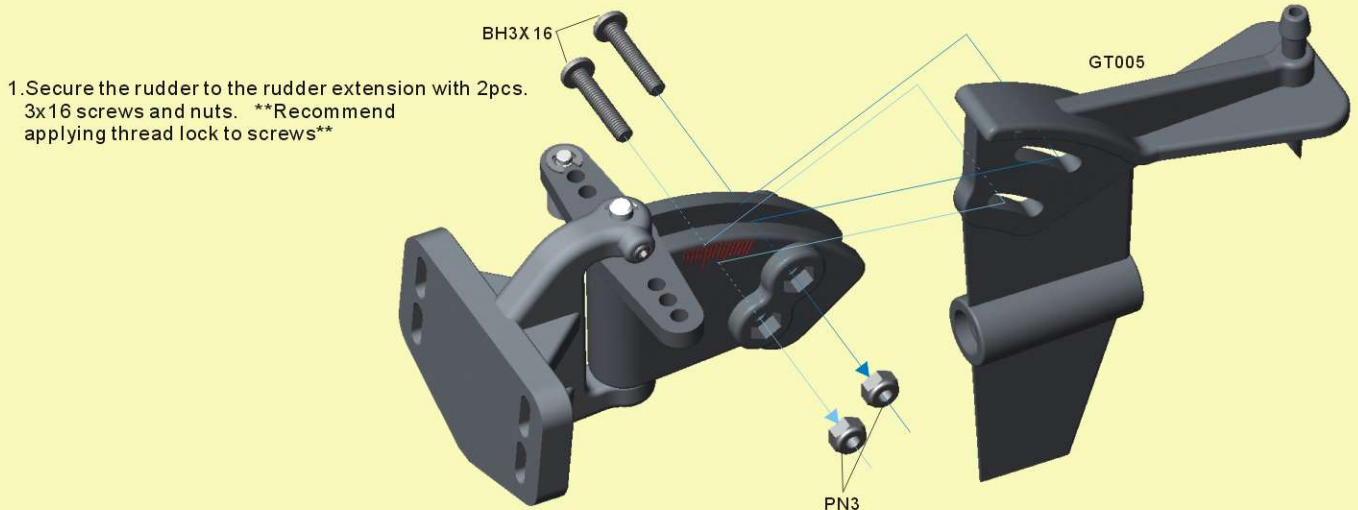

1. Secure the rudder to the rudder extension with 2pcs. 3x16 screws and nuts. **\*\*Recommend applying thread lock to screws\*\***

# 03 Propeller

GP EP

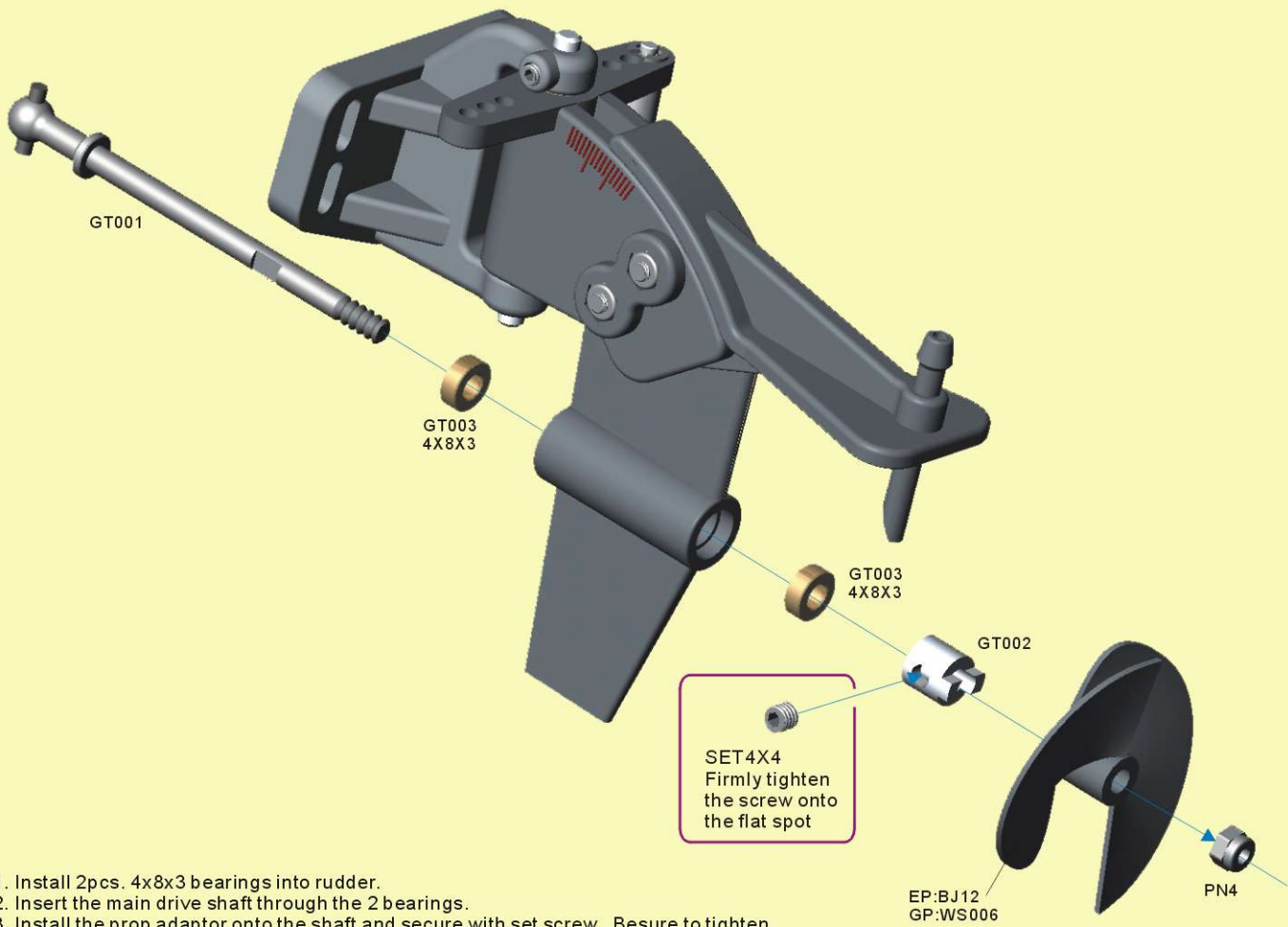

1. Install 2pcs. 4x8x3 bearings into rudder.
2. Insert the main drive shaft through the 2 bearings.
3. Install the prop adaptor onto the shaft and secure with set screw. Be sure to tighten down the set screw on the flat spot on the main shaft. \*\*Recommend applying thread lock to the set screw.\*\*
4. Align prop onto prop adaptor and secure with lock nut.

## CHECK

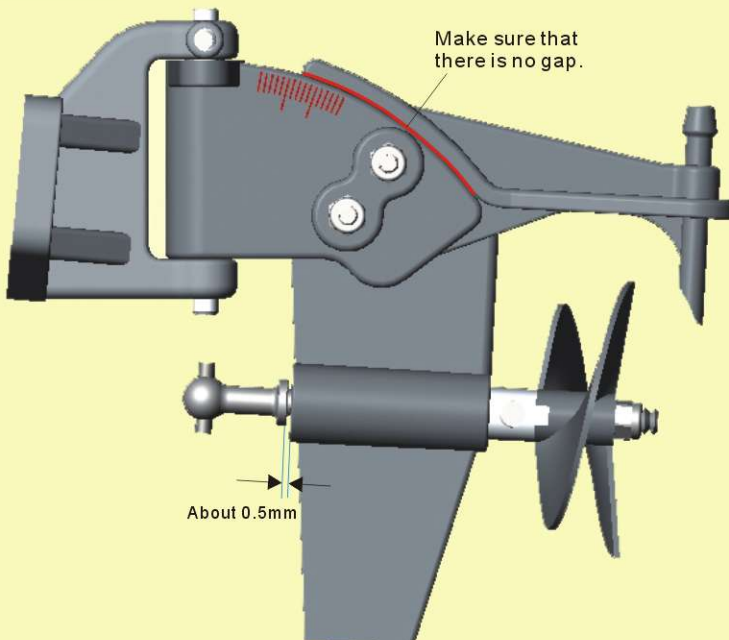

1. Your finished rudder assembly should look like this.

## 04 Motor

EP

1. Secure your 550/775 electric motor to the WS012 motor mount using the 2 supplied screws.
2. Secure your outdrive cup to the motor by tightening the set screw down onto the flat spot on the motor shaft.  
\*\*Recommend applying thread lock to screw\*\*

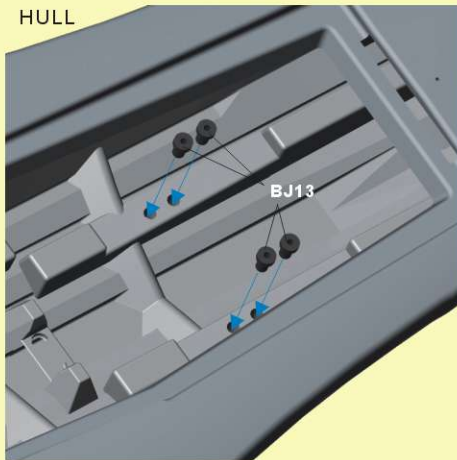
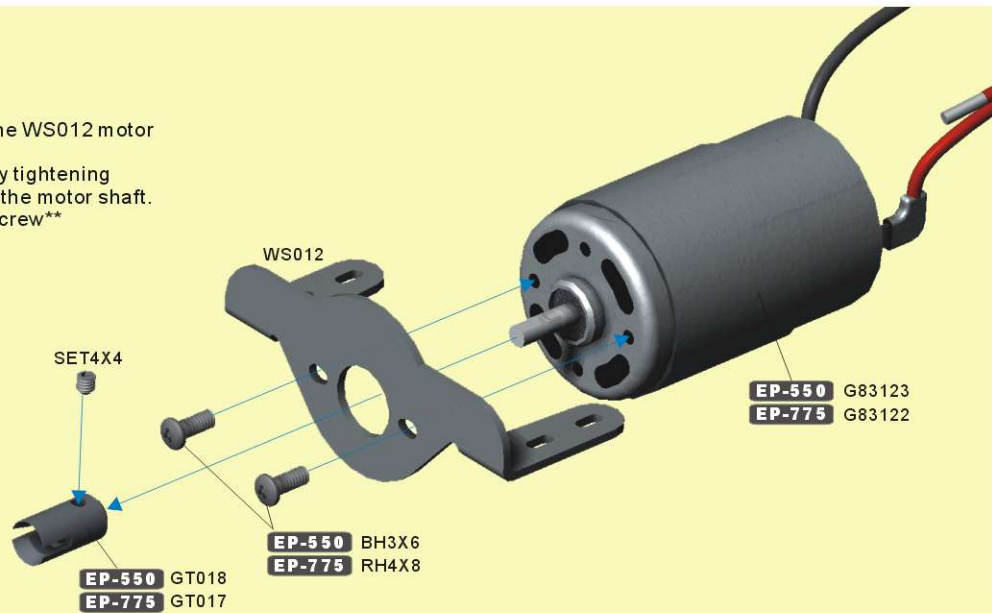

\*. Push 4 rubber garments into the 4 mounting holes in your hull.

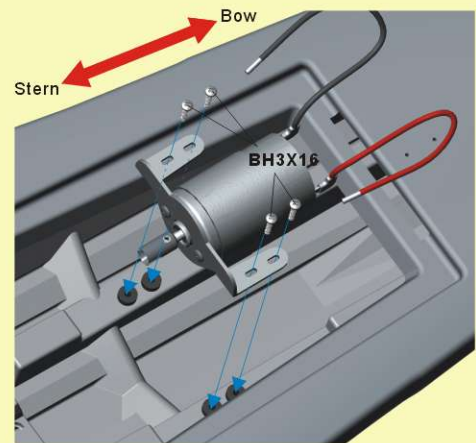

\*. Secure your electric motor mount to the hull by screwing 4pcs. 3x16 screws into the rubber garments. As you tighten the screws the garments will expand and hold the mount in.

## 05 Engine

GP

1. Secure the BJ23 engine mounts to your engine with 4pcs. 3x10 screws.  
\*\*Recommend applying thread lock to the screws.\*\*
2. Next secure your flywheel to the engine by tightening the outdrive nut.

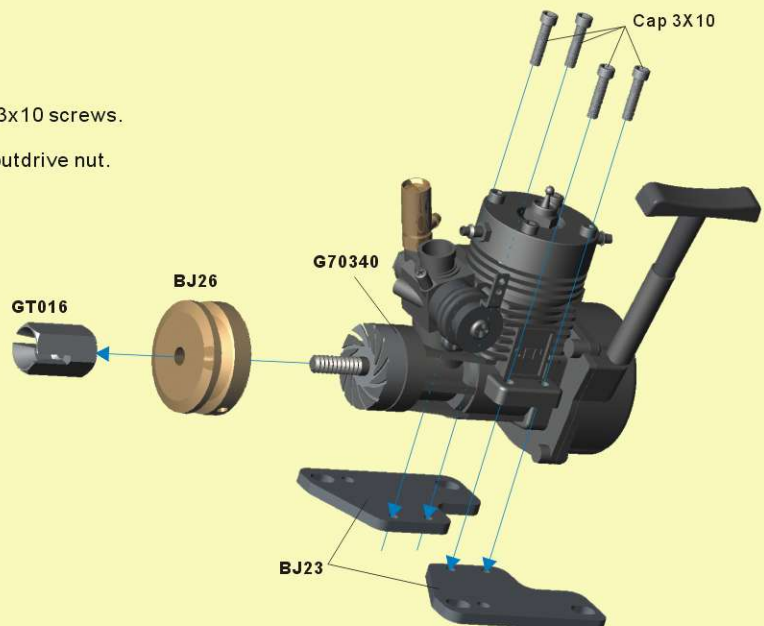

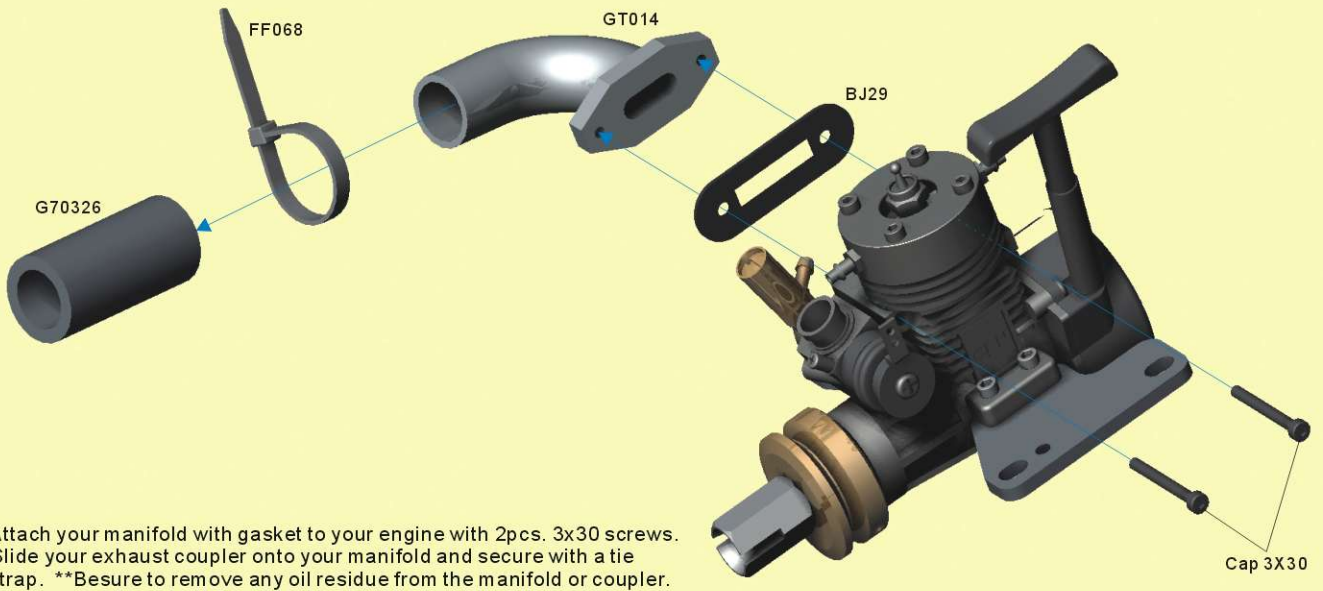

1. Attach your manifold with gasket to your engine with 2pcs. 3x30 screws.
2. Slide your exhaust coupler onto your manifold and secure with a tie strap. \*\*Besure to remove any oil residue from the manifold or coupler.

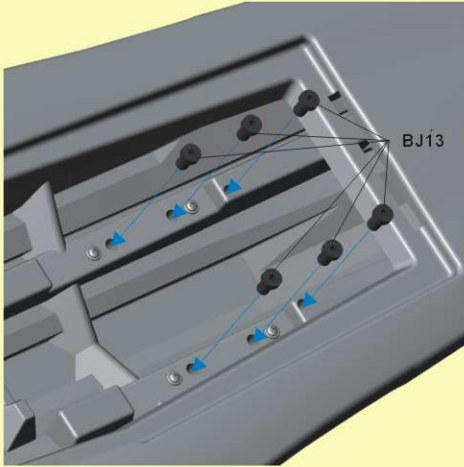

1. Push 6 rubber garments into the 6 mounting holes in your hull. Refer to picture for the correct locations.

1. Secure your engine to the hull by screwing 4pcs. 3x16 screws through your engine mounts and into the 4 rubber garments. The garments will expand when tightened and hole the engine in.

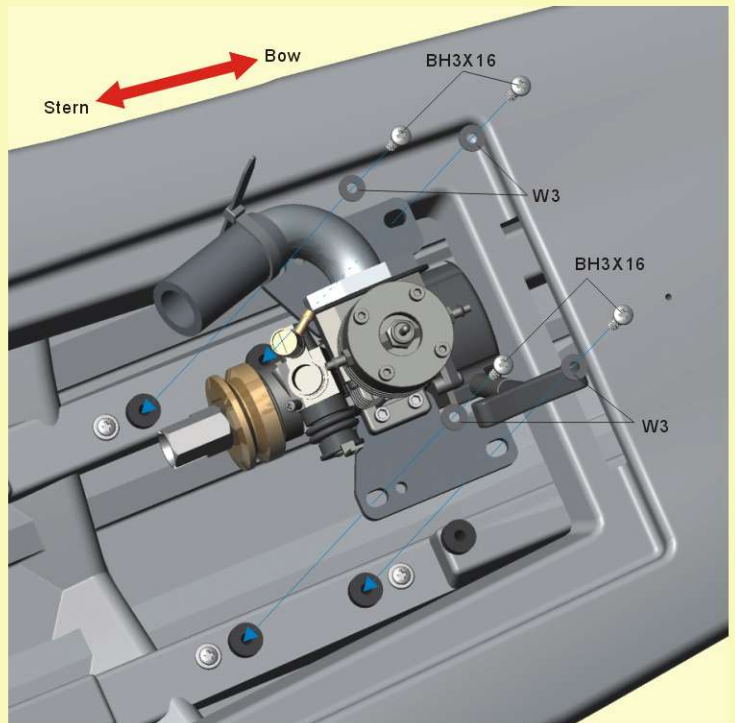

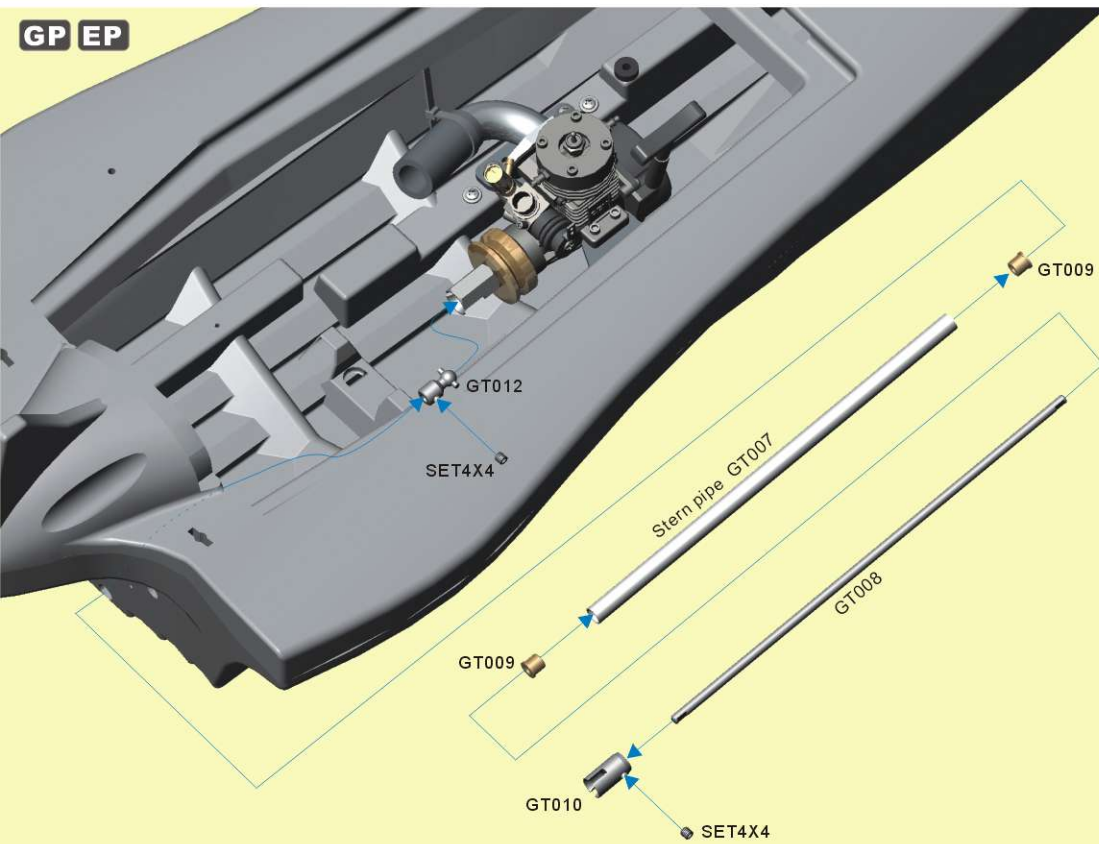

1. The following instructions should be used for both the nitro and electric version.
2. Insert rear rubber main shaft seal into the rear of the hull.
3. Slide shaft guide up through the hull. It helps if you moisten the seal to help the guide slide through. Leave about 16mm of the brass sleeve sticking out in the back.
4. Slide the main drive shaft up through the sleeve then secure the drive yoke to the main shaft by lining up the setscrew with the flat spot on the shaft. **\*\*Recommend applying thread lock to the set screw.\*\***
5. Next secure rear outdrive to the main shaft by tightening the setscrew down on the flat spot on the shaft. **\*\* Recommend applying thread lock. \*\***
6. You now need to secure and seal the brass sleeve/shaft guide with some high quality silicon sealant. Simply put the tip of the tube in the large opening in the hull that exposes the brass sleeve and squeeze. You want a good amount (but not too much) in there to properly seal and secure everything.
7. Now you should have your engine and drive shaft all installed.

1. Line up the prop shaft with the outdrive cup on the main shaft and secure rudder assembly using 4pcs. 3x12 screws.

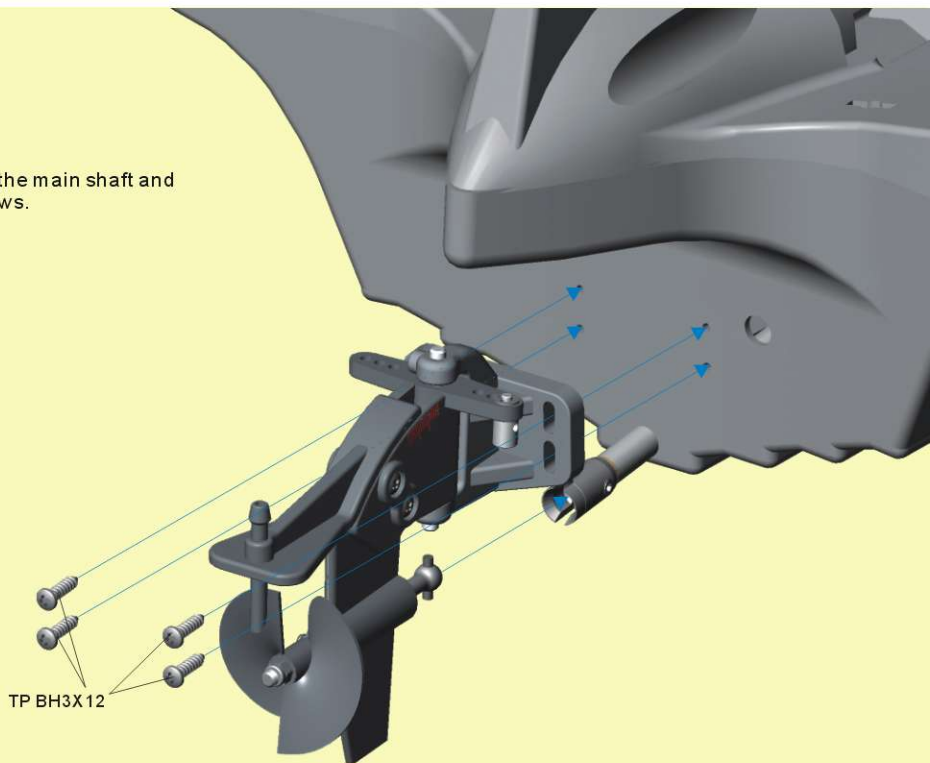



## CHECK

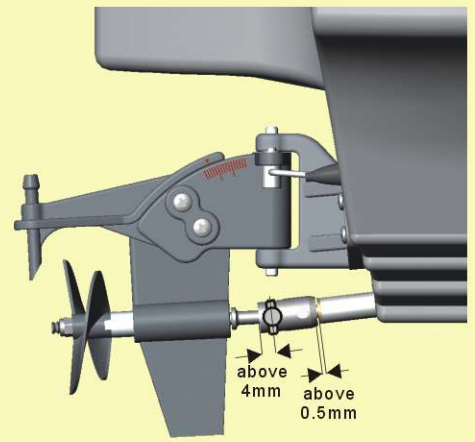
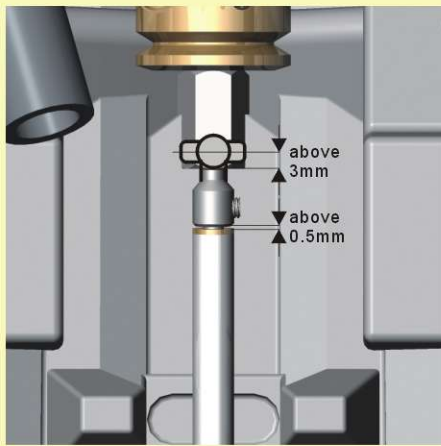

Check your work with these pictures. If you have a electric version, your should look the same just without the engine.

## CHECK

Make sure that stern pipe runs parallel to the center of the boat

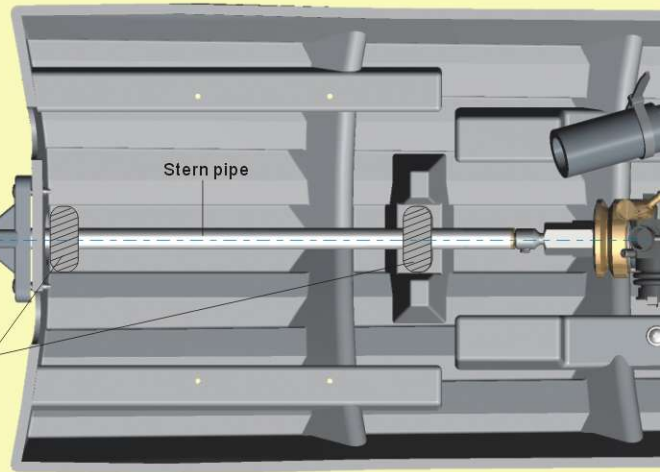
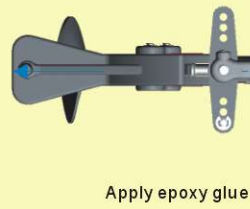

Check your work with these pictures. If you have a electric version, your should look the same just with out the engine.

## 07 Mech Plate

### GP EP

1. Secure your receiver and battery pack to the radio plate using 2 zip ties as shown in figure.
2. Secure the steering servo onto the radio plate using 4pcs. 3x10 screws. \*\*Notice the direction of the plate for correct placement.\*\*

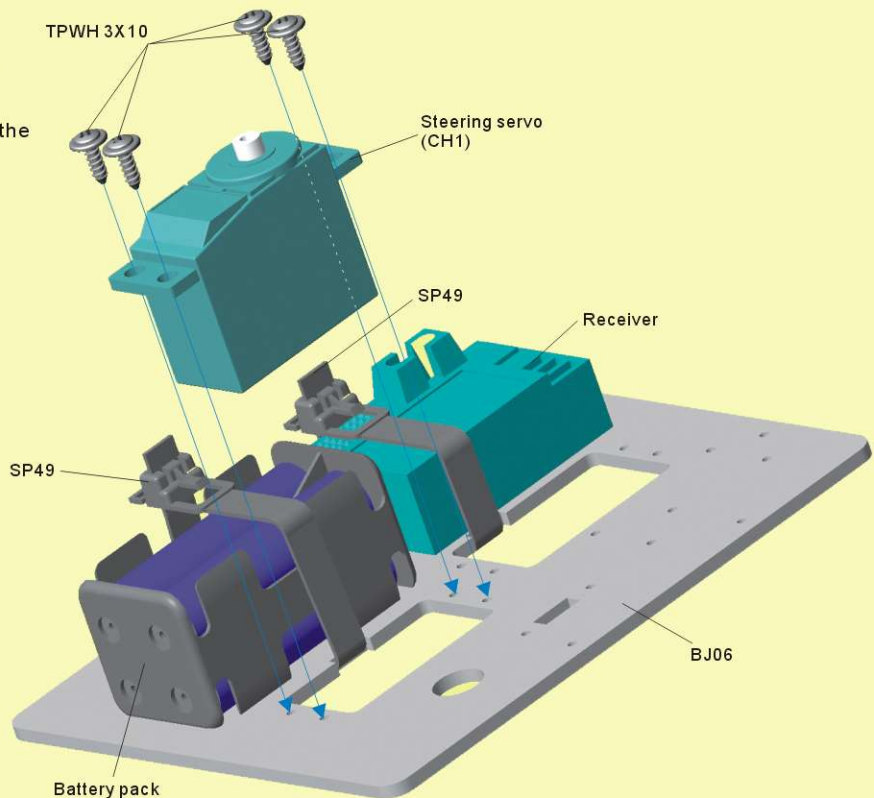

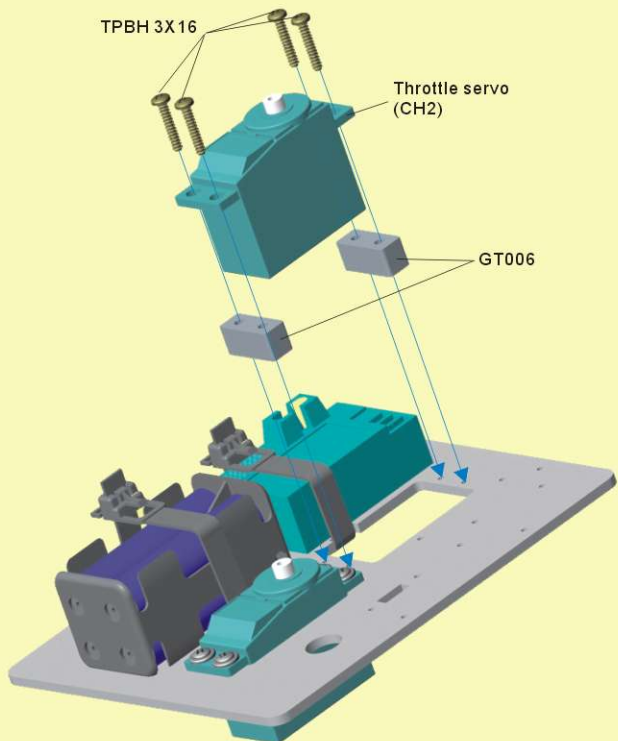

1. Secure your throttle servo with spacers using 4pcs. 3x16 screws. Please pay attention to the direction the servo is shown.

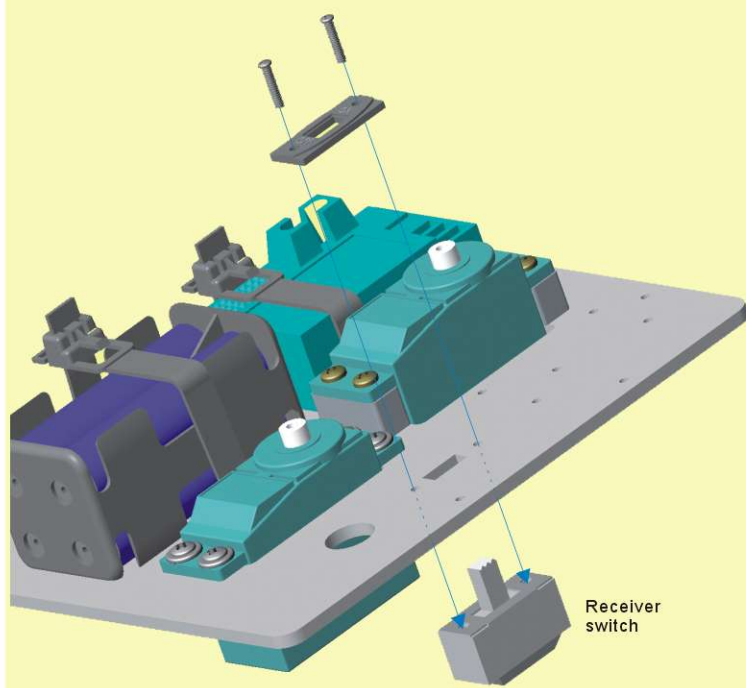

1. Mount your on/off switch onto the radio plate using 2 screws that were supplied with your switch.

1. Secure finished radio plate to the hull with 4pcs. 2.6x8 self-taping screws as shown.

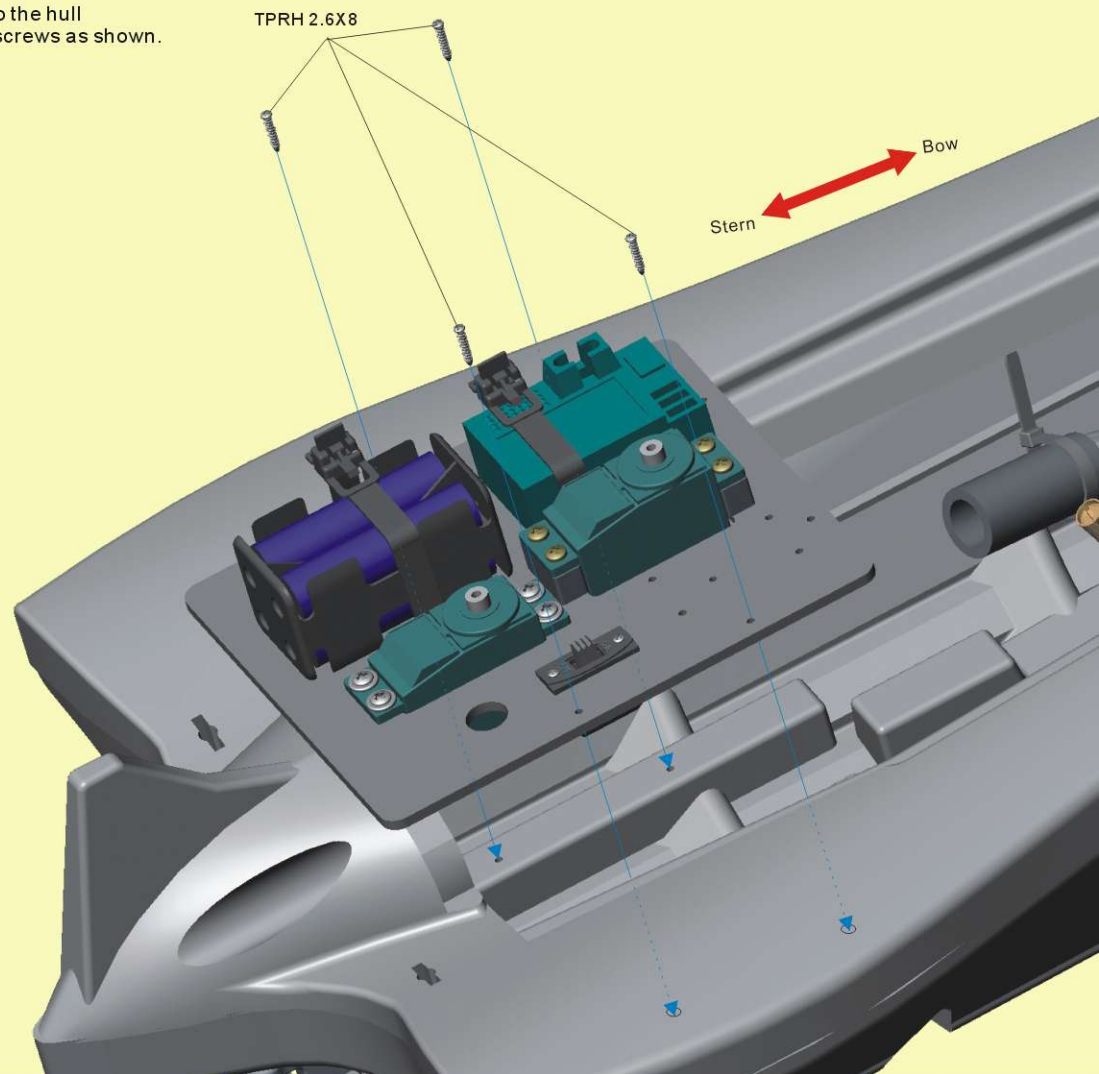

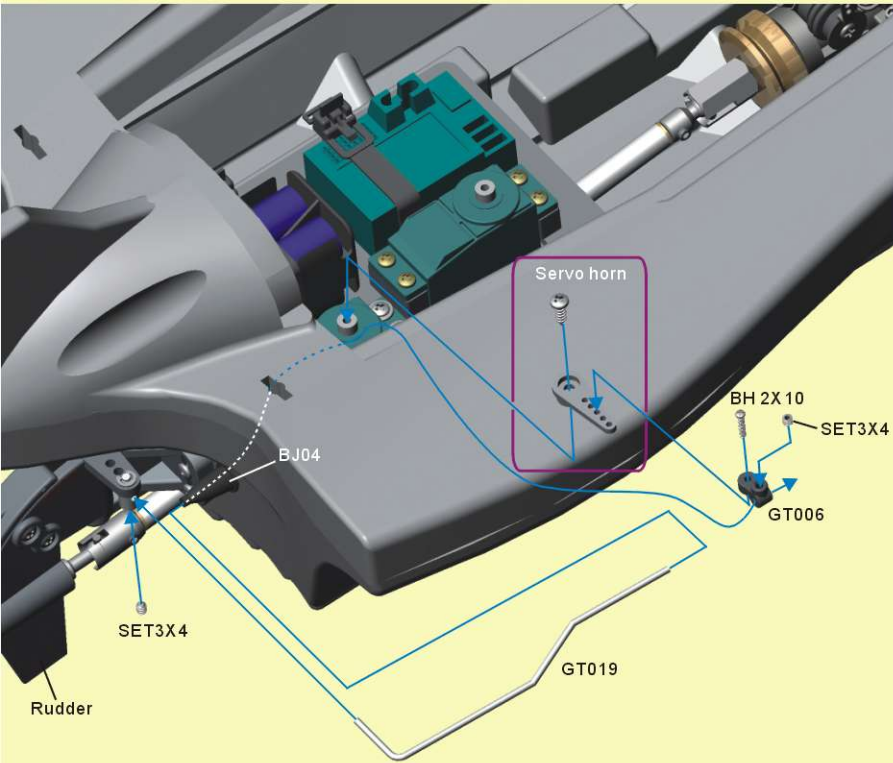

1. With your servo centered push your servo horn onto the servo. You want the horn to be 90° from the rubber. Secure the horn to the servo using the screw that came with the servo.
2. Secure the pivot joint to the horn using a 2x10 screw.
3. Insert a rubber rod seal into the right side rear of the hull.
4. Insert the steering rod through the rubber seal. You need the right angle part of the rod sticking out the rear of the hull. Refer to picture.
5. Put the end of the rod into the pivot joint. Next insert the front part of the rod onto the pivot joint on the horn. Position the rudder straight when the steering servo is centered and tighten the set screw in the pivot joint on the rudder. Next tighten the set screw in the front pivot joint on the horn.

## CHECK

1. Your finished steering linkage should look like this. Check your work and make any corrections needed.

Neutral position

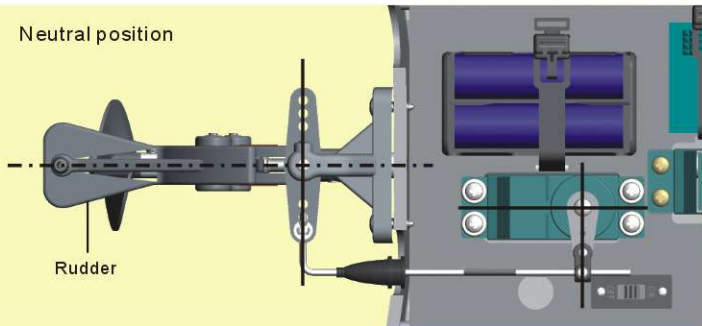

## 08 Micro Switch

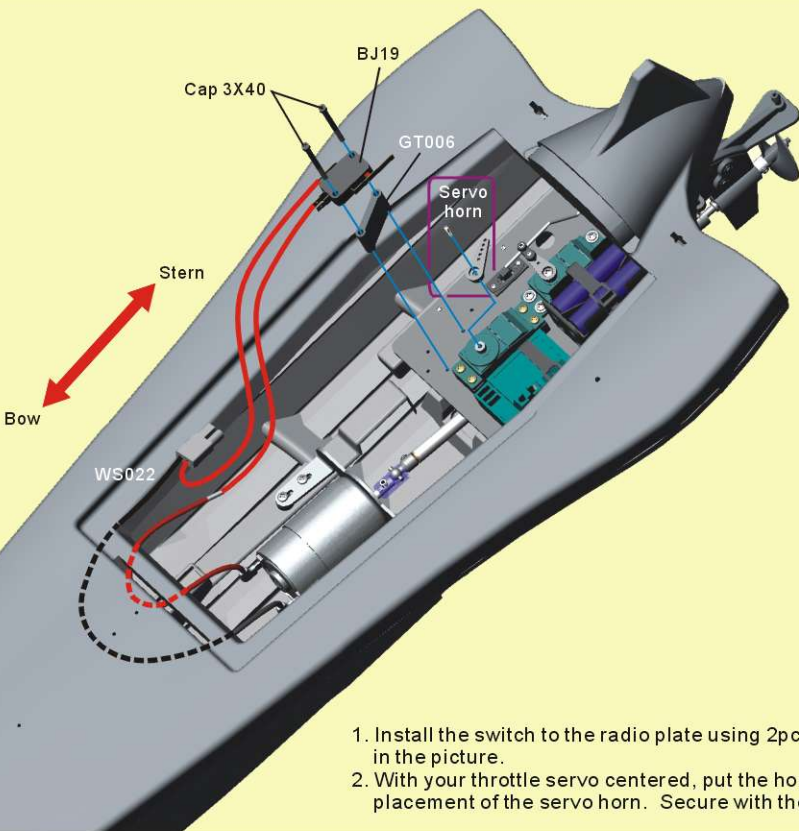

Adjust the horn could press the micro switch while it's action without over pressure to the strip

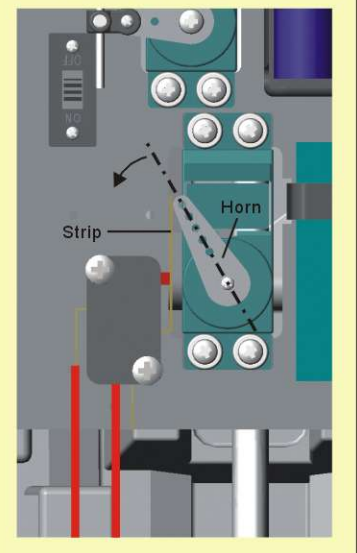

1. Install the switch to the radio plate using 2pcs. 3x40 screws as shown. Notice the direction of the switch in the picture.
2. With your throttle servo centered, put the horn onto the servo. Refer to figure for correct placement of the servo horn. Secure with the servo screw.

## EP-550

1. If you are using the 550 electric motor this is the correct way to install your 7.2volt battery. Using the supplied hook-&-loop tape, apply one side to both ends of your battery and the opposite side to the hull. This will secure the battery in the hull during use.

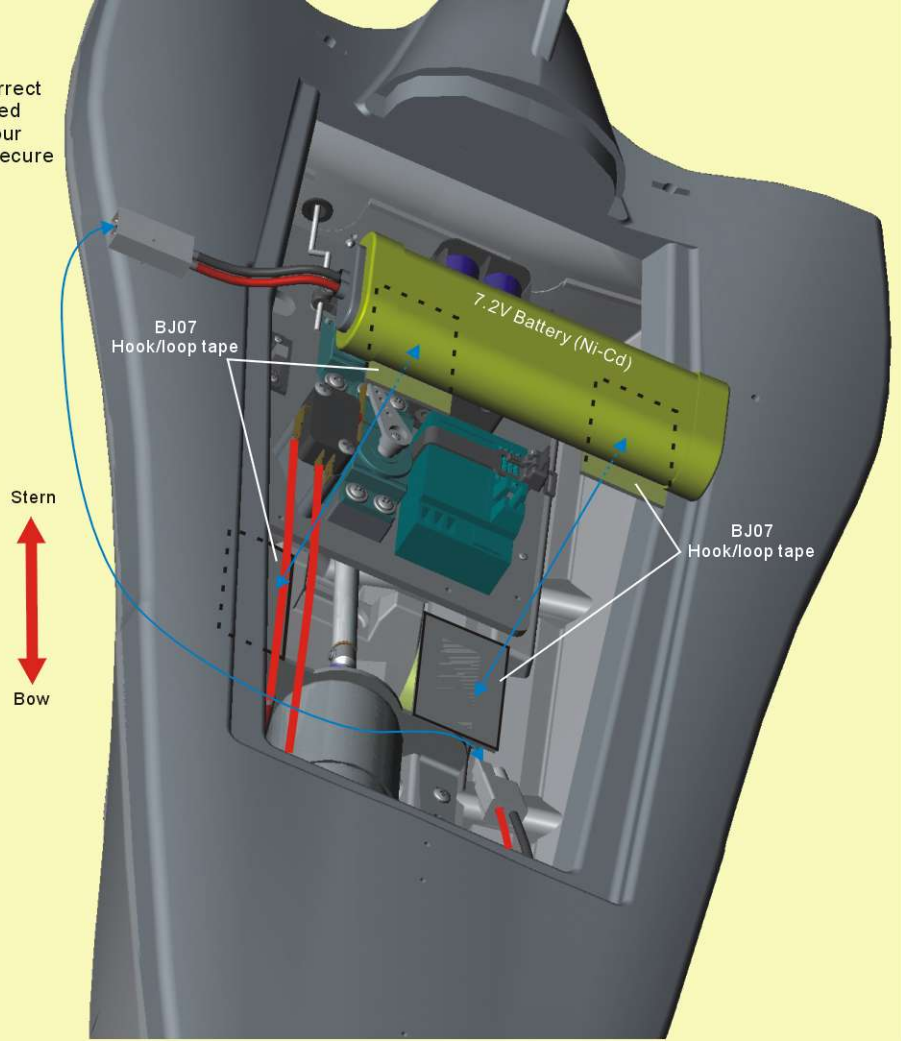

## EP-775

1. If you are using the 775 electric motor setup, then you are going to be using 2pcs. 7.2 volt batteries. You will be using the supplied "Y" connector to connect both batteries to the switch.
2. Using the supplied hook-&-loop tape, stick pieces on both your batteries. Stick the opposite side of the tape to the hull. This will secure your batteries in your hull during use.

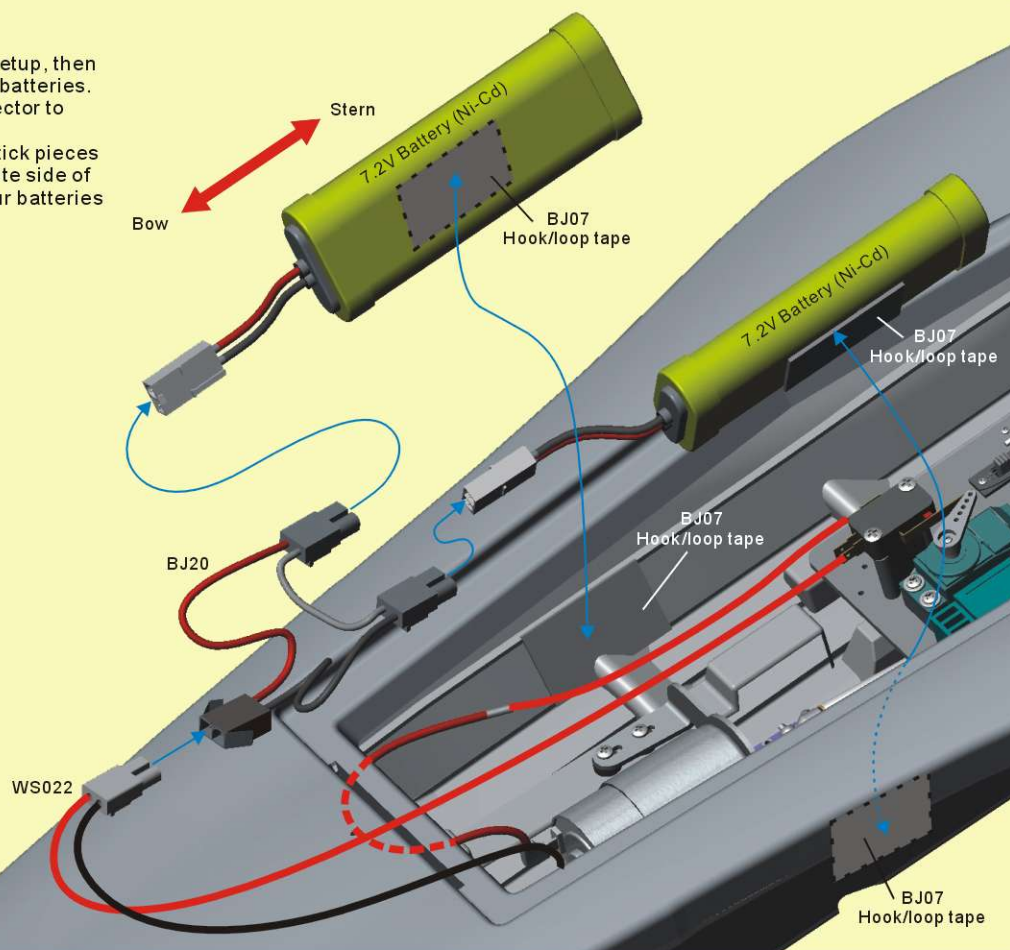

## 550 electric motor with micro switch

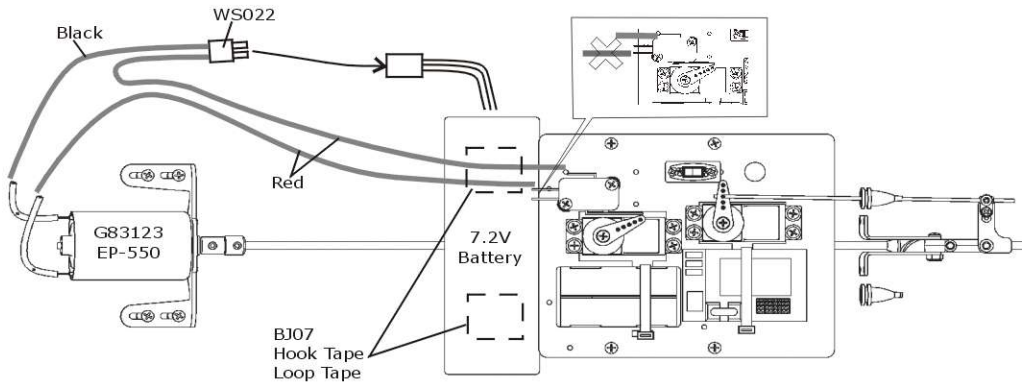

1. Find the WS022 battery plug. Solder the black (-) wire to the neg. (-) on the motor.
2. Connect the red (+) wire to the micro switch. \*\* Make sure you connect it to the correct terminal as pictured. \*\*
3. Find the red extension wire. Solder the red (+) to the pos (+) on the motor. Connect the other side of the wire to the micro switch. \*\*Make sure to connect to the terminal as pictured. \*\*
4. Double-check all your work. Incorrect wire could result in serious damage to your electronics.
5. Connect the battery pack. Hold boat off table and test for correct operation. The motor should work when the micro switch is pushed on.

## 550 electric motor with Electronic Speed Controller

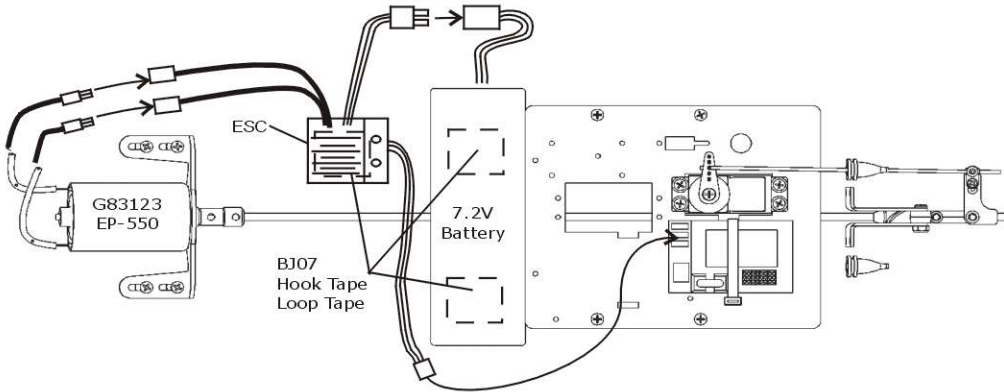

1. Solder the red (+) wire with plug to the pos. (+) on the motor. Repeat those steps again except solder the black (-) wire with plug to the neg. (-) on the motor.
2. Using double-sided tape, mount your ESC in your hull.
3. Plug the receiver wire into channel 2 in the receiver.
4. Connect your motor wires to the ESC by matching red-to-red and black-to-black.
5. Double-check all your work. Incorrect wire could result in serious damage to your electronics.
6. Connect your battery. Next turn on your transmitter. Push the set-up switch on your ESC to turn the unit on.
7. Now it's time to set-up the speed controller. Jump to section for ESC setup for instructions.

## 775 electric motor with micro switch

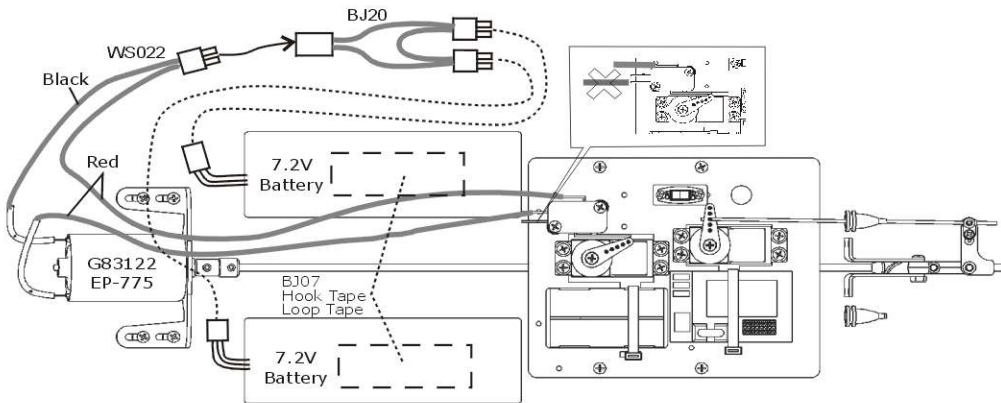

1. Find the WS022 battery plug. Solder the black (-) wire to the neg. (-) on the motor.
2. Connect the red (+) wire to the micro switch. \*\* Make sure you connect it to the correct terminal as pictured. \*\*
3. Find the red extension wire. Solder the red (+) to the pos (+) on the motor. Connect the other side of the wire to the micro switch. \*\*Make sure to connect to the terminal as pictured. \*\*
4. Double-check all your work. Incorrect wire could result in serious damage to your electronics.
5. Connect BJ20 "Y" connector to the WS022 plug. Now connect both of your 7.2-volt batteries to the "Y" connector.
6. Double-check all your work. Incorrect wiring can result in serious damage to your electronics.
7. Hold boat off table and test for correct operation. The motor should work when the micro switch is pushed on.

## 775 electric motor with Electronic Speed Controller

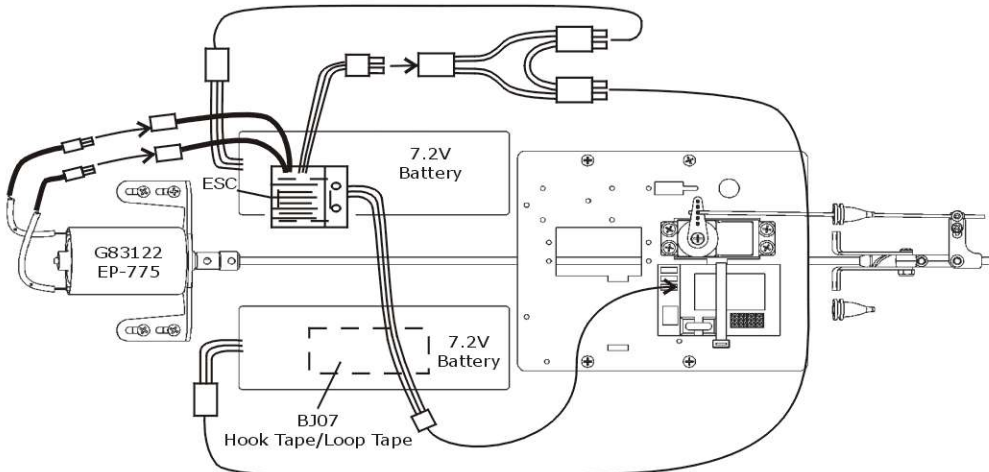

1. Solder the red (+) wire with plug to the pos. (+) on the motor. Repeat those steps again except solder the black (-) wire with plug to the neg. (-) on the motor.
2. Using double-sided tape, mount your ESC in your hull.
3. Plug the receiver wire into channel 2 in the receiver.
4. Connect your motor wires to the ESC by matching red-to-red and black-to-black.
5. Connect the "Y" connector to the male battery plug from the ESC.
6. Double-check all your work. Incorrect wire could result in serious damage to your electronics.
7. Connect both 7.2-volt batteries to the "Y" connector. Next turn on your transmitter. Push the set-up switch on your ESC to turn the unit on.
8. Now it's time to set-up the speed controller. Jump to section for ESC setup for instructions.

# 10 ESC(electronic speed controller)

## EP-550

1. Solder the red (+) wire with plug to the pos. (+) on the motor. Repeat those steps again except solder the black (-) wire with plug to the neg. (-) on the motor.
2. Using double-sided tape, mount your ESC in your hull.
3. Plug the receiver wire into channel 2 in the receiver.
4. Connect your motor wires to the ESC by matching red-to-red and black-to-black.
5. Double-check all your work. Incorrect wire could result in serious damage to your electronics.
6. Connect your battery. Next turn on your transmitter. Push the set-up switch on your ESC to turn the unit on.
7. Now it's time to set-up the speed controller. Jump to section for ESC setup for instructions.

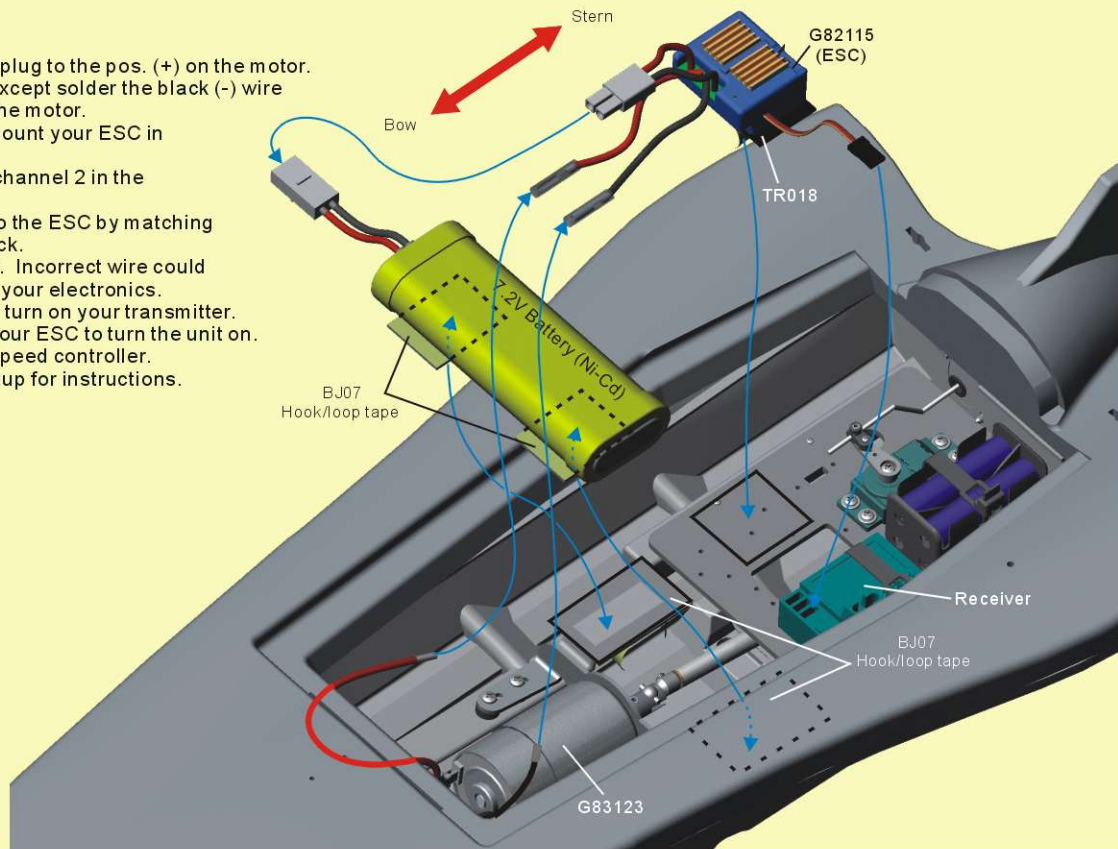

## EP-775

1. Solder the red (+) wire with plug to the pos. (+) on the motor. Repeat those steps again except solder the black (-) wire with plug to the neg. (-) on the motor.
2. Using double-sided tape, mount your ESC in your hull.
3. Plug the receiver wire into channel 2 in the receiver.
4. Connect your motor wires to the ESC by matching red-to-red and black-to-black.
5. Connect the "Y" connector to the male battery plug from the ESC.
6. Double-check all your work. Incorrect wire could result in serious damage to your electronics.
7. Connect both 7.2-volt batteries to the "Y" connector. Next turn on your transmitter. Push the set-up switch on your ESC to turn the unit on.
8. Now it's time to set-up the speed controller. Jump to section for ESC setup for instructions.

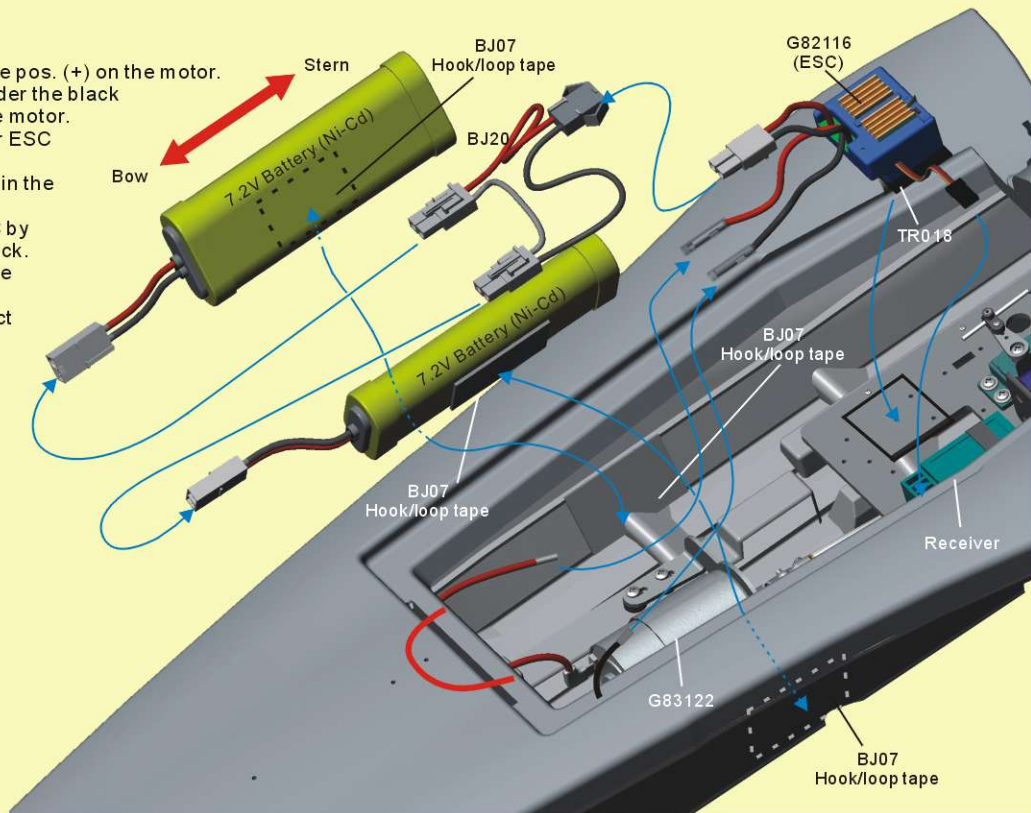

## Electronic Speed Controller set-up procedures

**Switch on-** press ESC switch and hold for 2 seconds.

**Switch off-** press ESC switch and hold for 3 seconds.

### Standard set-up

With speed controller and transmitter both turned on follow the following steps.

1. Press and hold ESC button for about 5 seconds until the L.E.D. light goes off then release.
2. The L.E.D. will be flashing slowly, with the transmitter trigger in neutral position press the ESC button once.
3. Now the L.E.D. will be double flashing. Pull the trigger all the way back and while holding the trigger back press the ESC button once.
4. Now the L.E.D. will be triple flashing. Push the trigger forward for full brake, while holding press the ESC button once.
5. Set-up is now complete.

# 11 Tank, Muffler

GP EP

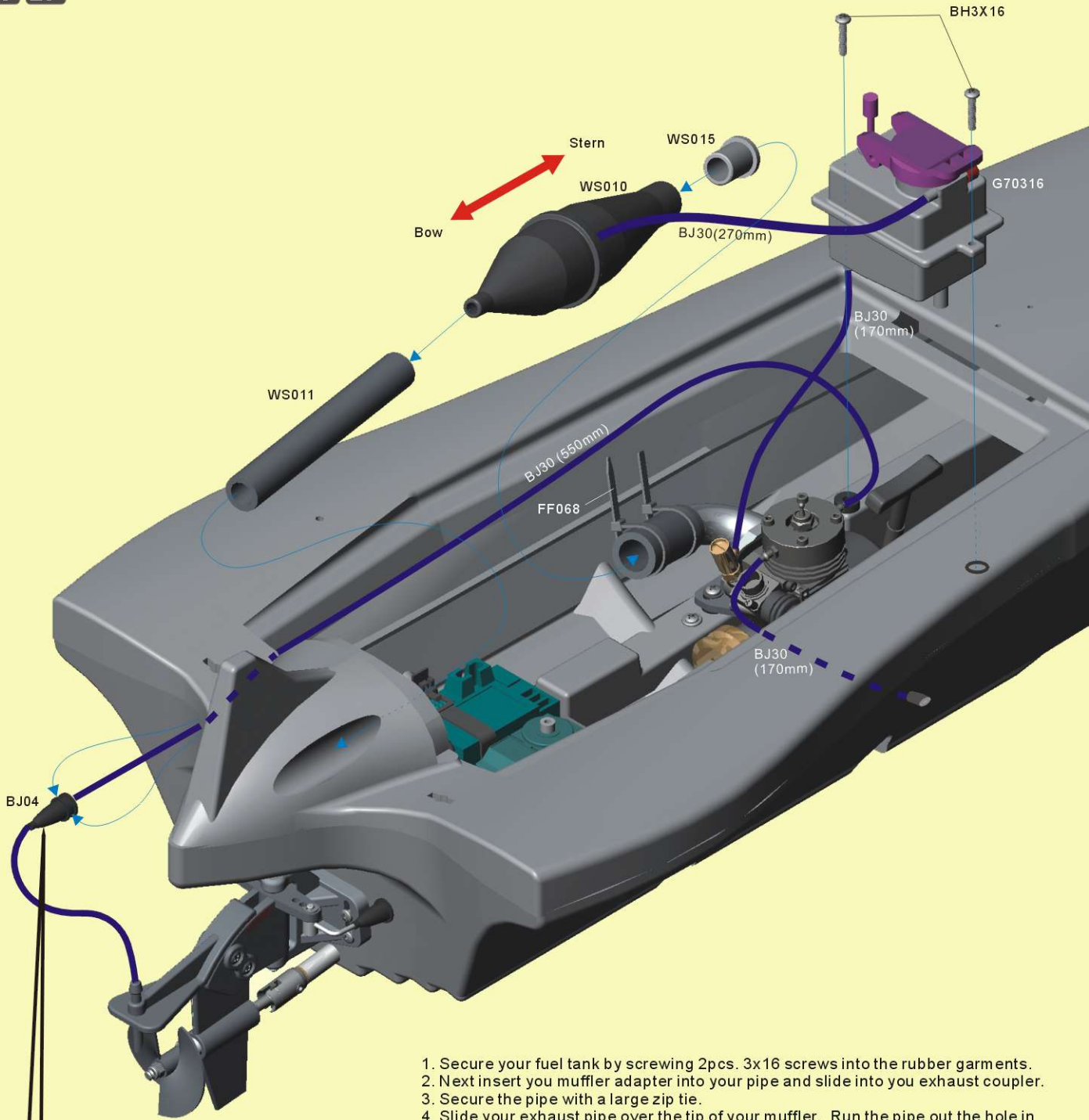

1. Secure your fuel tank by screwing 2pcs. 3x16 screws into the rubber garm ents.
2. Next insert you muffler adapter into your pipe and slide into you exhaust coupler.
3. Secure the pipe with a large zip tie.
4. Slide your exhaust pipe over the tip of your muffler. Run the pipe out the hole in the rear of your hull. Exhaust pipe will become very hot during use.

## Water proof cup

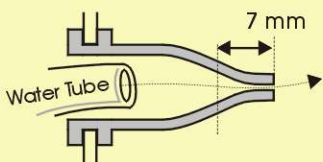

Trim away the front of water proof cap and let the cooling tube to through it.

1. Now you need to hook up your throttle linkage. Find your throttle linkage rod and put the "Z" bent side into the lower hole on the carburetor arm.
2. With your throttle servo centered, push the horn onto the servo and secure with the servo screw.
3. Secure the pivot joint to the 3rd hole on your horn with a 2x10 screw.
4. Next push your carburetor all the way closed and tighten the setscrew on the pivot joint.
5. When you pull the trigger back on your controller check to see if your carburetor is opening all the way up.

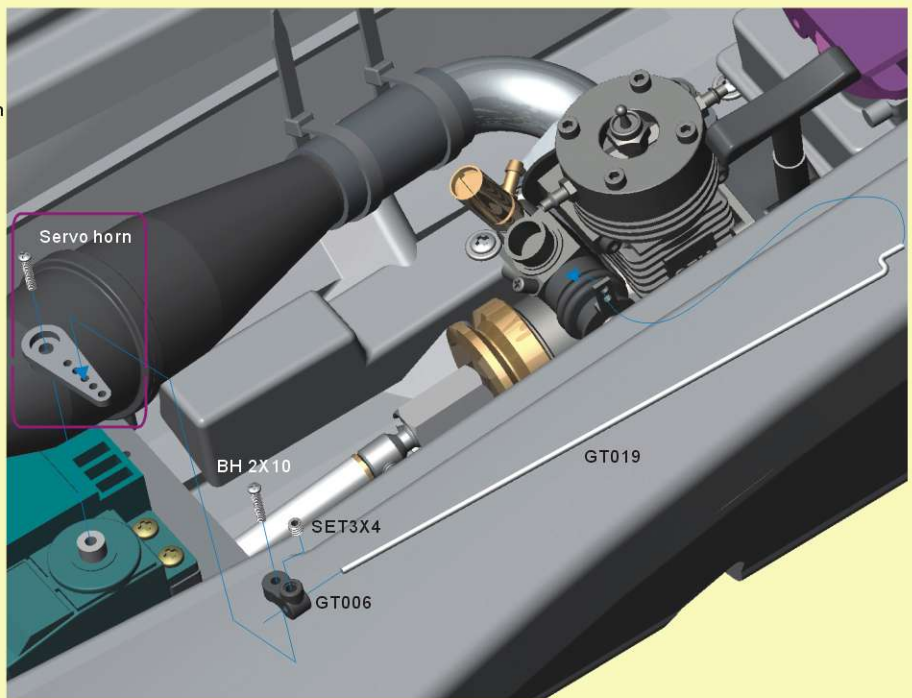

## 12 Hand Rail (GT006)

GP EP

1. First slide the plastic pieces onto the rod as shown.
2. Next attach the plastic pieces to the hull using super glue

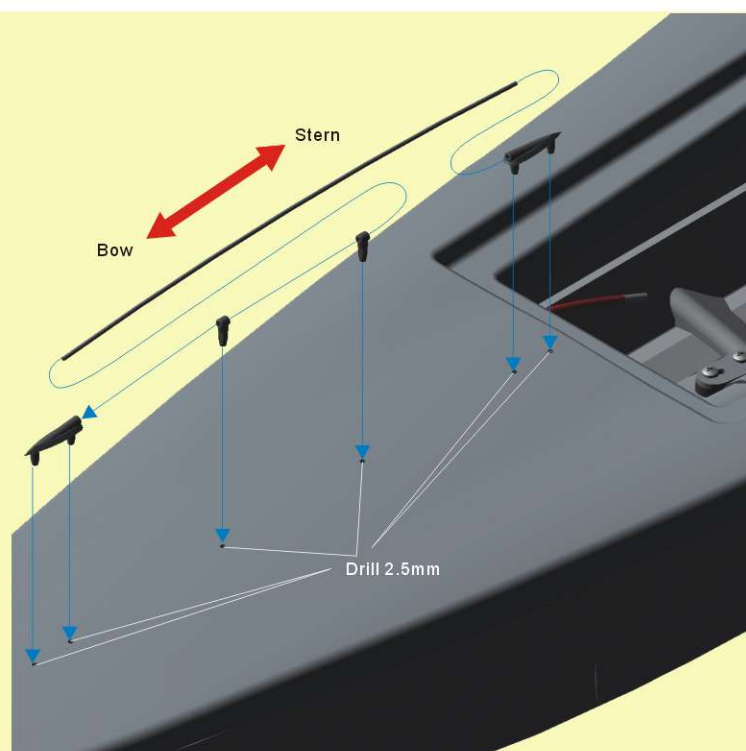



# 13 Cabin

## GP EP

1. Assemble the cabin latches to the cabin as shown in picture to the right.
2. Install the bottom part of the latch up through the cabin.
3. Then put the spring followed by the top of the latch. Secure assembly with the 2x10 screw.

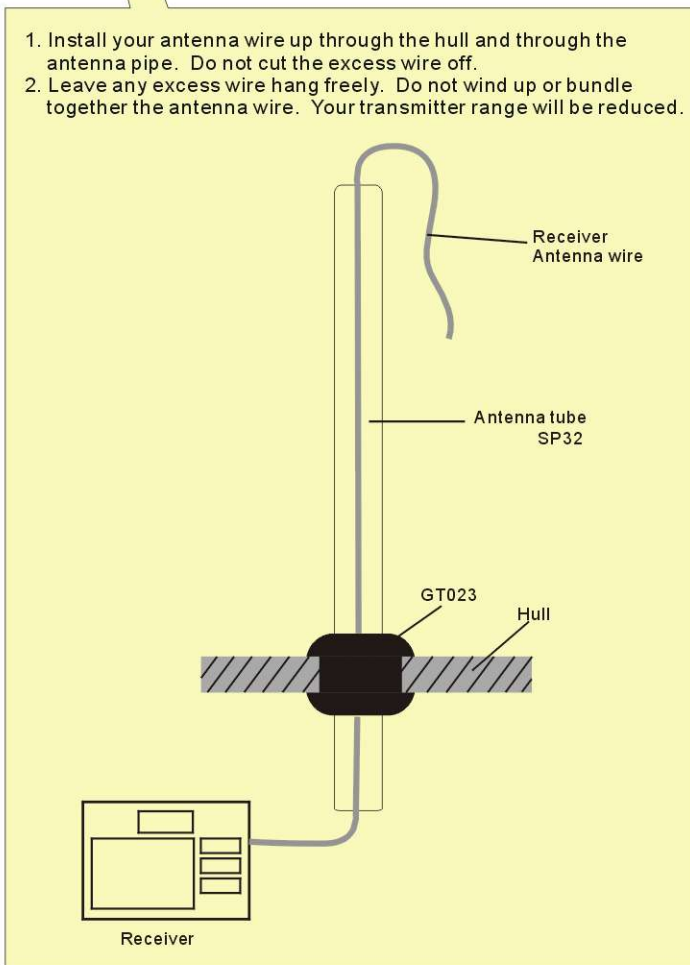
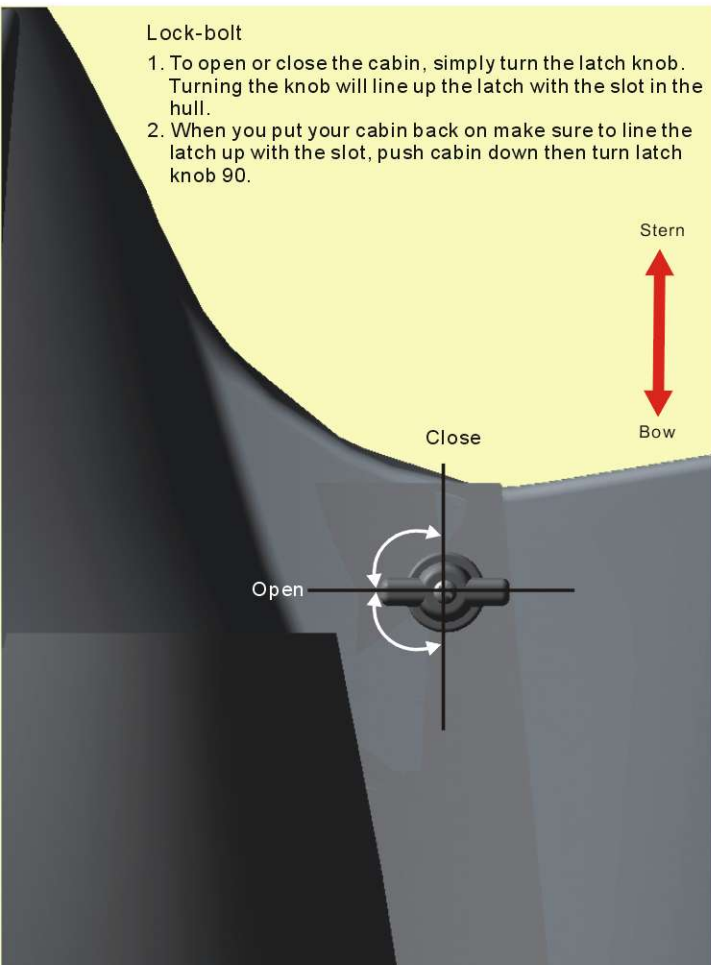
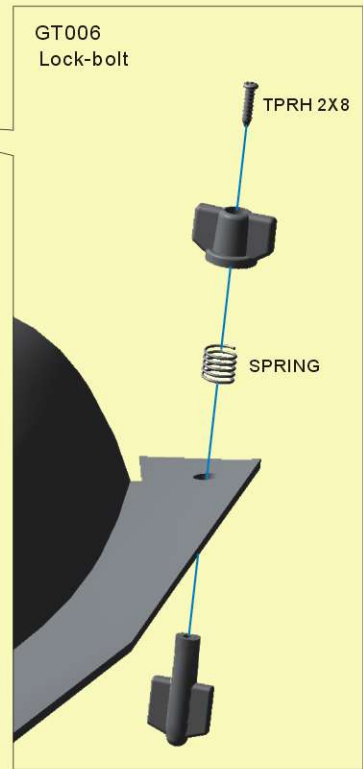
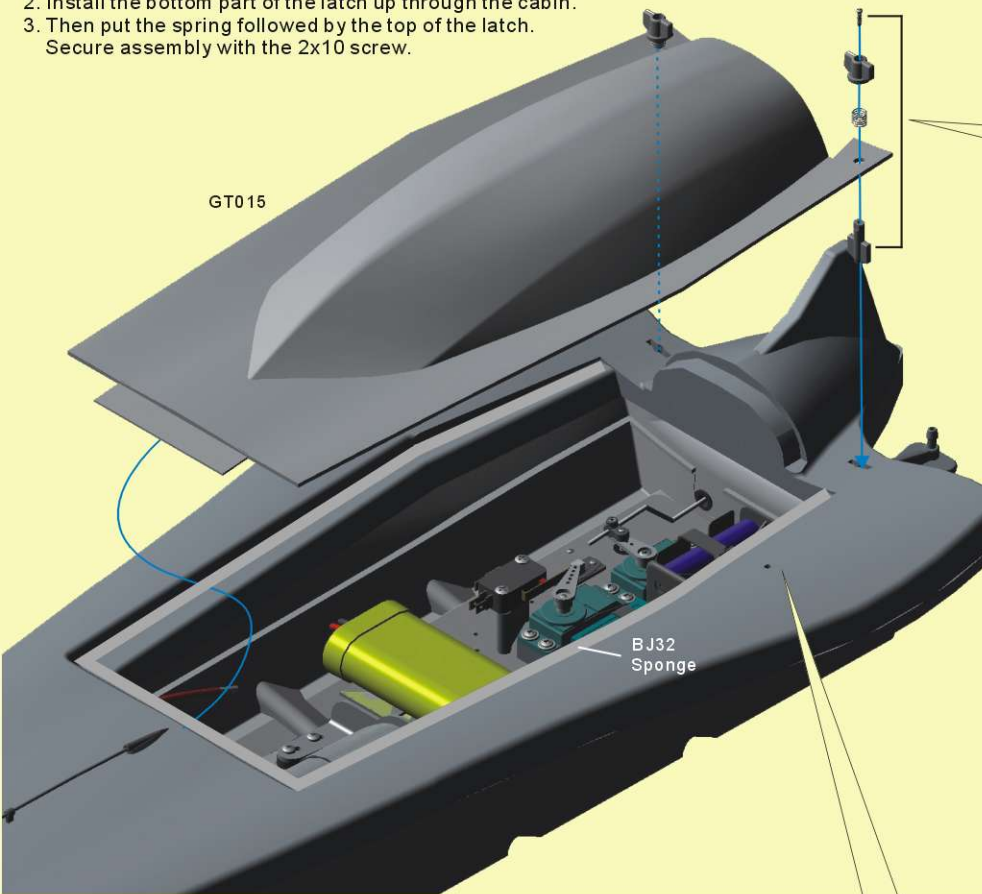

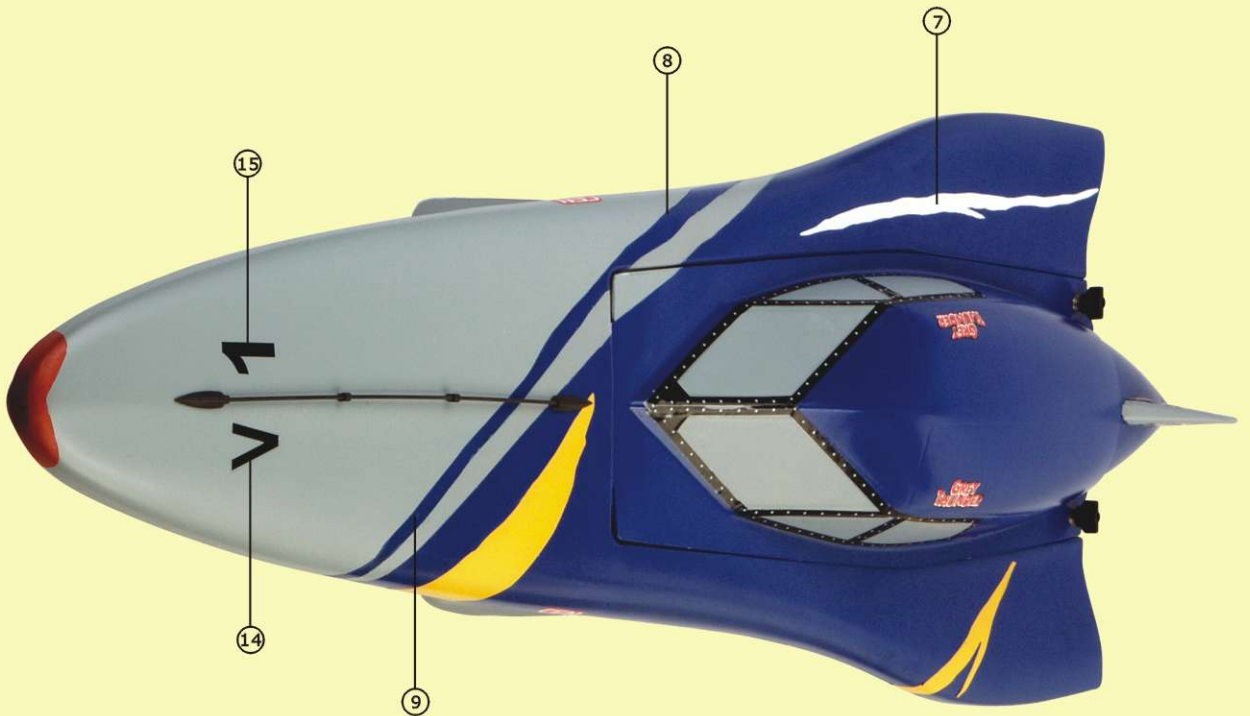

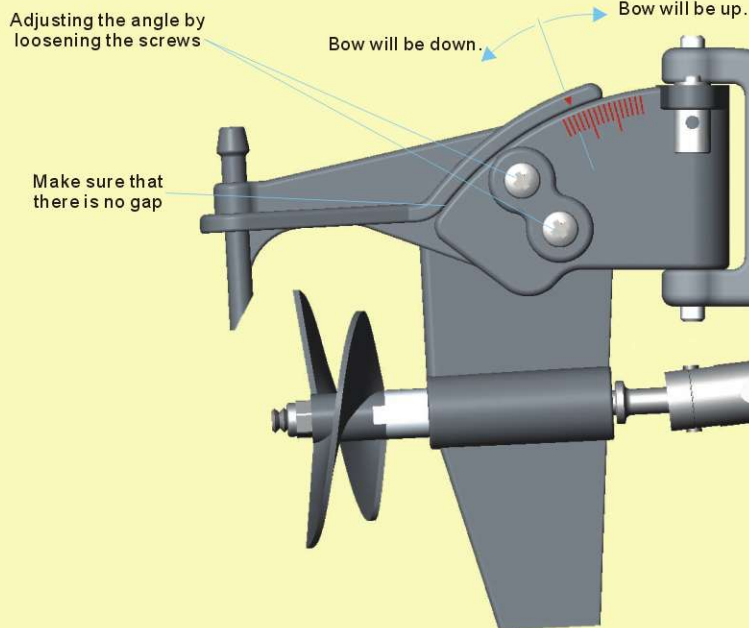

### Engine Tuning

This section is going to help you understand the adjustments on your carburetor. No adjustments are exact because so many things play a part in how your engine runs. Once you get your engine tuned and running, you will still need to make minor adjustments due to changes in weather conditions, fuel types, and even age of engine. You also need to understand that all engines, even if the brand and type will have slightly different carburetor adjustments.

The two worst enemies of model engines are heat and or dirt. If you overheat the engine it will burn up the piston/sleeve and will need to be replaced for correct operation. If your engine sucks dirt inside, it may damage the entire engine. Boats really don't have much problem with dirt because they are on water, but it's definitely something you should be aware of.

Fuel is one of the most important ingredients required for a smooth running engine. Please only use a high quality brand name fuel. When choosing a fuel don't pick the lowest cost bottle at the store. Go with what the shop recommends. We recommend you use 40-45 % airplane fuel in your boat. After testing many different types and combinations, we found this to be the best for both performance and tuning. Many people use car model fuels between 20-30%, which is ok, but the engine does not tune or run as well.

Do not run your engine out of water for long periods of time. Since its water-cooled, it may overheat. It is ok to start, and warm-up slightly before putting it in the water. Let the cooling head on the engine fill up with water before driving off to the center of the lake. Sometimes in cold water, the engine may stall until it can get up to running temperature.

### Engine settings

Your carburetor has three adjustment screws. One is for the top-end, the second is for the low-end and the third is to set the idle. These adjustments are sensitive. When making final adjustments make them at 1/12 of a turn at a time. Just think of it as a clock.

**Top-end needle**, This is located on the top of the carburetor, the screw has a brass sleeve around it. This is also called the main needle adjustment. A good starting point for this adjustment is 3 full turns out. Screw the needle all the way in until it stops, then unscrew 3 full turns. Once you get your engine running smoothly this should be the only adjustment you really will need to mess with.

**Low-end needle**, This is also sometimes called your bottom end needle. You will find this adjustment on the side of the carburetor. It is in the center of the carburetor arm. A good starting point for this is 3 1/2- 4 turns out after screwed all the way in. Once you get your engine at running temperature check this adjustment by doing the following, Rev the engine up, then let of the trigger and listen to the engine idle down. Wait about 5-10 seconds and listen to the idle, you want it to idle consistently. If you hear the idle rise slightly then you need to richen the bottom slightly (turn to the left). If the idle drops, then lean the bottom slightly (turn to the right).

**Idle screw**, This screw is under the air intake. This screw controls the idle by preventing how much the carburetor closes. It's basically only a stop screw. One **important** thing is always open the carburetor slightly before tightening the screw. Not doing so may snap the tip of the screw off inside your engine. If your engine is stalling when idling then you need to raise the idle up (turn screw to the right). You want the idle high enough so the engine does not stall. If the engine sounds like it's idling too high then you need to lower it slightly (turn to the right).

You should keep your engine running under 220° F. You may check this by putting a drop of water on the head. The water should sit there for at least 5-seconds. If the water evaporates immediately then your engine is running too hot, this means it's too lean. To cool the engine down turn your top-end needle to the left 1/8" of a turn. Run for a minute then re-check.

I hope you truly took your time to read and follow all these instructions. Not doing so may damage your boat or void your warranty. These instructions are to help you get more fun and use out of the model.

# Safety Precautions

- Whether you run your boat on lakes, rivers or elsewhere, take precautionary measures to avoid accidents.
- The motor and Ni-Cd battery get hot from running. Do not touch them for a while after running.
- Only use golw fuel for radio control models! Never use gasoline or kerosene which might cause accidents such as fires.
- Never put the charger and Ni-Cd battery near flammable material while charging as this may cause fires.
- Do not dispose of battery and empty fuel can into a fire, it might explode causing serious injury. Please get information from the The Environment Protection Bureau or R/C model shop.
- Do not put your hands or any objects into rotating parts, as this could result in serious accidents.
- For accident prevention, do not run you boat as following:
  - a. Near School, the Telecommunications bureau and Hospitals.
  - b. Make sure that nobody is using the same frequency as you at the same time.
  - c. When radio batteries are run down.
  - d. When your boat control or running behavior is strange.

## "Greythunder" boat & parts list

No.	Name
BJ04	Waterproof cap
BJ06	Mech. Plate
BJ07	Hook/loop magic tape
BJ12	Propeller 42 x 1.4
BJ13	Damper nut
BJ19	Micro switch
BJ20	Tri-connector
BJ23	Engine mount
BJ26	Flywheel
BJ29	Gasket
BJ32	Waterproof sponge
FF068	Mid. Cable tie
FF072	Servo horn
G70316	Fueltank 75cc
G70326	Silicon exhaust coupler
G70340	Marine engine NX-16
G83122	Motor 775

No.	Name
G83123	Motor 550 (with cooling fan)
GT001	Propeller shaft
GT002	Propeller drive
GT003	Metal bushing 4x8x3
GT004	Rudder hinge pin
GT005	Rudder, bracket
GT006	GT plastic small parts
GT007	Stern pipe
GT008	Stern shaft
GT009	Metal flange bushing
GT010	Drive cup (Rudder side)
GT011	Hull (Greythunder) -EP
GT012	Drive ball
GT013	Pivot
GT014	Manifold
GT015	Cabin(Greythunder)
GT016	Hull (Greythunder) -GP

No.	Name
GT017	Drive cup-EP-775
GT018	Drive cup-EP-550
GT019	Drive cup-GP
GT020	Controlled rod
GT021	GT(Greythunder) screws set
GT022	GT(greythunder) stand
GT023	3mm Rubber bushing
GT024	Decal-Greythunder
SP32	Antenna pipe
SP49	Large cable tie
SP50	Small cable tie
WS006	Propeller 40x1.6
WS010	Muffler
WS011	Exhaust pipe
WS012	Motor mount
WS015	Muffler adaptor
WS022	Connector

## "Greythunder" optional parts



BJS03 Waterproof bag



G70346 Cooling head for NX-16 engine



SP56 Resistor for rotary speed controller



G73909 Marine ball bearing 4x8x3



G73910 Marine flange bearing 4x7



BJS01 Cooling coil tube (EP-550)  
BJS02 Cooling coil tube (EP-775)



G82115 ESC Conquest-B ( for 550 motor)  
G82116 ESC Conquest-775 (for 775 motor)



BJ34 Rotary speed controller set



### CENCHAIN CO., LTD.

No.16, LANE 105, CHENG FU RD,  
SANHSIA, TAIPEI HSIEN TAIWAN, R.O.C  
TEL: 886-2-26681881  
FAX: 886-2-26681899  
E-mail: rchobby@ms11.hinet.net

### CEN/GTC

1800 E. Miraloma Ave., #F,  
Placentia, CA 92870 USA  
TEL: 1-714-792-1923  
FAX: 1-714-792-1968  
E-mail: sales@cenracing.com

### IRVINE LTD.

UNIT 2, BRUNSWICK IND. PARK  
BRUNSWICK WAY  
NEW SOUTHGATE  
LONDON N11 1JL UK  
Tel: +44 (0) 208-361-1123  
Fax: +44 (0) 208-361-8684  
E-mail:sales@lrvineitd.com

### MHD

272,avenue Henri-Barbusse  
59581 MARLY Cedex, France  
Tel: +33 (0)3 27 45 00 24  
Fax: +44 (0)3 27 45 63 65  
E-mail:ofontaine@scientific-mhd.com

### SIMPROP ELECTRONIC

Ostfelde 5  
D-33428 Harsewinkel  
German  
Tel: +49-(0)-5247-604-56  
Fax: +49-(0)-5247-604-15

<http://www.cenracing.com>



## Grey Thunder

mit Elektro-Motor 550  
mit Elektro-Motor 775  
mit Verbrennungsmotor NX-16 Marine

Modellbau vom Besten  
**Krick**

Bestell-Nr. 24000  
Bestell-Nr. 24004  
Bestell-Nr. 24008



Fastfertig-Modell eines ferngesteuerten Rennbootes mit eingebautem Antrieb. Je nach Version mit Elektro-Motor 550 oder Elektro-Motor 775 oder Verbrennungsmotor NT16 Marine

Technische Daten:

Gesamtlänge	820 mm
Breite	270 mm
Höhe	170 mm
Schiffsschraube	Rennschraube Dogdrive
Antrieb	Einwellen-Direktdrive
Gewicht	ab 1900 g

Änderungen vorbehalten! Für Druckfehler wird keine Haftung übernommen. Stand April 2003

# Ersatzteile für Grey Thunder

Krick Bestell-Nr.	CEN Teile-Nr.	Artikelbezeichnung	Version
24204	BJ04	Gestängedurchführung Boote	Alle
24206	BJ06	Schalterbefestigungsplatte	Alle
24207	BJ07	Klettband	Alle
24212	BJ12	Schiffschraube 42 mm Ø x 1,4	EP
24213	BJ13	Halterung Kunststoff GP	GP
24219	BJ19	Motorschalter	EP
24220	BJ20	Y-Kabel JST Stecker	EP 775
24223	BJ23	Motorträger RC-Boote GP	GP
24226	BJ26	Schwungscheibe Aqua Jet	GP
24229	BJ29	Auspuff-Dichtung	GP
24232	BJ32	Kab.deck Dichtung	Alle
24233	BJ33	Gummi Tüllen	Alle
611680	FF068	Kabelbinder mittel	Alle
611720	FF072	Servohorn	Alle
613032	SP32	Antennenrohr	Alle
613049	SP49	Kabelbinder wiederverschließbar groß	Alle
613050	SP50	Kabelbinder klein	Alle
617316	G70316	Tank 75 ccm	GP
617326	G70326	Siliconschlauchberbindung	GP
617340	G70340	NX-16 Marinemotor m. Seilzugstarter	GP
42121	G83123	Elektromotor 550 mit Gebläse	EP 550
42120	G83122	Elektromotor 775 mit Gebläse	EP 775
24301	GT001	Ruderschaft Grey Thunder	Alle
24302	GT002	Drivedog	Alle
24303	GT003	Sinterlager 4x8x3 Grey Thunder	Alle
24304	GT004	Ruderachse Grey Thunder	Alle
24305	GT005	Ruder Grey Thunder	Alle
24306	GT006	Kabinenverriegelung Grey Thunder	Alle
24307	GT007	Stevenrohr Grey Thunder	Alle
24308	GT008	Stevenwelle Grey Thunder	Alle
24309	GT009	Sinterlager f. 24307 Grey Thunder	Alle
24310	GT010	Mitnehmer Ruderseite Grey Thunder	Alle
24311	GT011	Rumpf Grey Thunder EP	EP
24312	GT012	Mitnehmer m. Kugel f. Stevenwelle	Alle
24313	GT013	Gestängeanschluß	Alle
24314	GT014	Kümmer Grey Thunder	GP
24315	GT015	Kabinendeckel Grey Thunder	Alle
24316	GT016	Rumpf Grey Thunder GP	GP
24317	GT018	Mitnehmer f. 550 3,17 mm	EP 550
24318	GT017	Mitnehmer f. 775 5 mm	EP 775
24319	GT019	Mitnehmer f. NX-16 GT	GP
24320	GT020	Gestängesatz Grey Thunder	Alle
24321	GT021	Schraubenset Grey Thunder	Alle
24322	GT022	Schiffsständer Grey Thunder	Alle
24323	GT023	Gummi Tüllen 3mm	Alle
24324	GT024	Dekorsatz Grey Thunder	Alle
613032	SP32	Antennenrohr	Alle
613049	SP49	Kabelbinder wiederverschließbar groß	Alle
613050	SP50	Kabelbinder klein	Alle

Krick Bestell-Nr.	CEN Teile-Nr.	Artikelbezeichnung	Version
24406	WS006	Schiffschraube 40mm Ø x 1,6	GP
24410	WS010	Schalldämpfer RC-Boote GP	GP
24411	WS011	Auspuffverlängerung Grey Thunder	GP
24412	WS012	Motorträger EP	EP
24415	WS015	Distanzstück Auspuff	GP
24422	WS022	Verbinder	

## Tuningteile Grey Thunder

Krick Best.Nr.	CEN Best.Nr.	Artikelbezeichnung	
42122	BJS01	Wasserkühlschlange f. 550 Motor	EP 550
42123	BJS02	Wasserkühlschlange f. 775 Motor	EP 775
42190	BJS03	Wasserschutz f. Empf. + Akku	Alle
617346	G70346	Extrem-Wasserkühkopf NX-16 blau	GP
24234	BJ34	Mech. Fahrtregler RC-Boote	EP
613056	SP56	Widerstand für mech. Fahrtregler	EP
24325	G79909	Kugellager 4x8x3	Alle
24326	G73910	Kugellager mit Bund 4x7	Alle
67015	G82115	Elektronischer Fahrtregler Conquest B	EP 550
67016	G82116	Elektronischer Fahrtregler Conquest B 775	EP 775

# Ersatzteile für **CEN** NX-16 Marine V-Motor

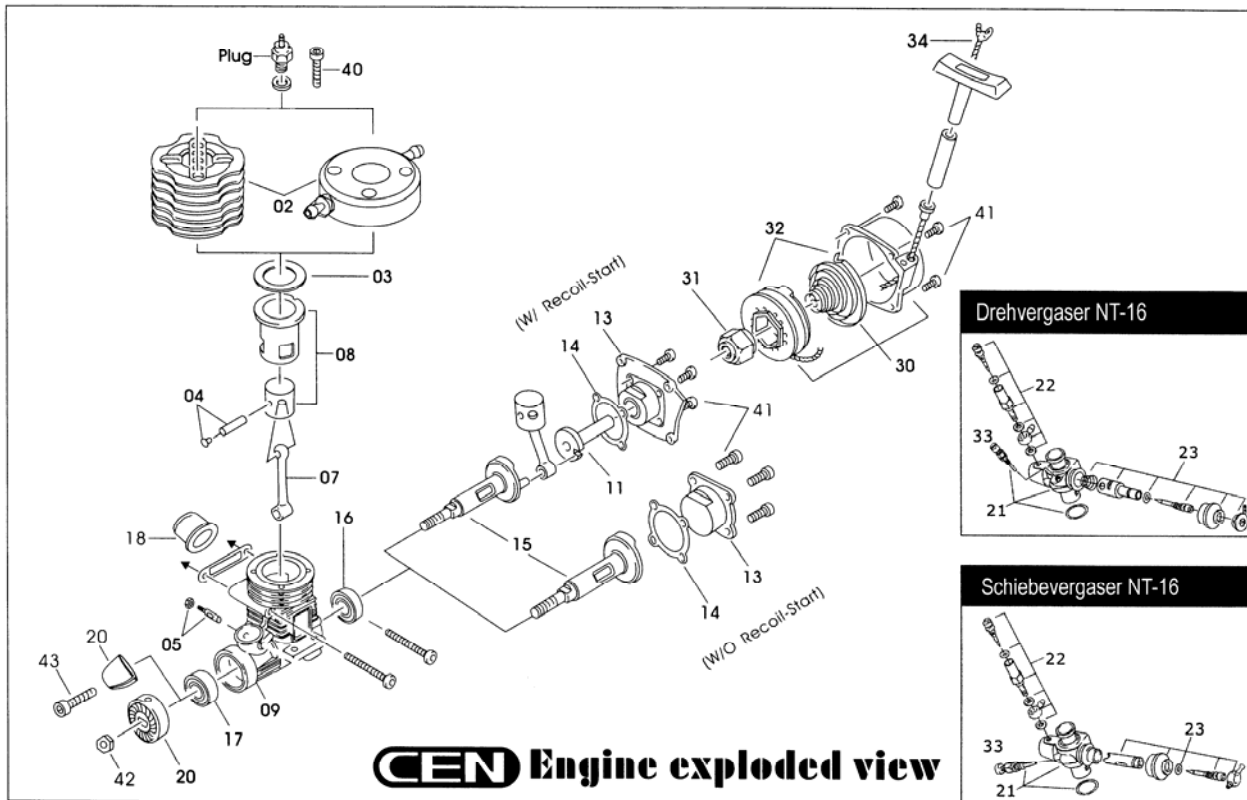

**CEN** Engine exploded view

Krick Bestell-Nr.	CEN Teile-Nr.	Artikelbezeichnung	Teile-Nr. (Abb.)
617340	G70340	NX-16 Marine Verbrennungsmotor kpl.	
617760	G70340-02	Extremkühlkopf	02
617761	G70340-03	Zylinderkopf-Dichtung	03
617762	G70340-04	Kolbenbolzen	04
617725	G70337-05	Vergaserklemmung	05
617763	G70340-07	Pleul	07
617764	G70340-08	Laufgarnitur	08
617769	G70343-09	Kurbelwellegehäuse	09
617729	G70337-10	Vergaser	10
617730	G70337-11	Einwegkupplungswelle	11
617731	G70337-13	Gehäusedeckel	13
617732	G70337-14	Gehäusedeckel-Dichtung	14
617765	G70340-15	Kurbelwelle	15
617734	G70337-16	Hinteres Kugellager	16
617735	G70337-17	Vorderes Kugellager	17
617736	G70337-20	Mitnehmer	20
617737	G70337-21	Vergasergehäuse	21
617738	G70337-22	Hauptdüsenadelset	22
617739	G70337-23	Vergaserküken u. Nadelset	23
617766	G70340-30	Seilzugstarter kpl.	30
617741	G70337-31	Einwegkupplung f. Seilzugstarter	31
617742	G70337-32	Seilzugstarterfeder	32
617743	G70337-33	Standgasanschlagschraube	33
617744	G70337-34	Seilzugstarterseil	34
617767	G70340-40	Zylinderkopfschraube	40
617746	G70337-41	Gehäuseschrauben	41
617747	G70337-42	Kurbelwellenmutter	42



Mehr Informationen entnehmen Sie dem aktuellen Krick-Katalog oder unter [www.krick-modell.de](http://www.krick-modell.de)